

KTS-0

Fire Damper - round

Technical Documentation



 1438	
SMAY Sp. z o.o. 17 CSWU: 1438-CPR-0528 DWU: 019-CPR-2017	
EN 15650:2010 Fire damper type: KTS-O-E,KTS-O-S	
Nominal activation conditions/sensitivity: Closing/opening during the test at the right time	Pass
Response time/Closure time:	Pass
Reliability	50 cycles <120S
Fire resistance:	
Fire integrity - E Fire insulation - I Smoke leakage - S Mechanical stability (under E) Maintenance of the cross section (under E)	EI 120 (ve h _o i↔o) S EI 90 (ve i↔o) S EI 60 (ve i↔o) S EI 30 (ve i↔o) S
Durability:	
Opening and closing cycle test	KTS-O-E: 10 000 cycles <120S KTS-O-S: 100 cycles <120S

Version 6.4

SMAY reserves the right to make changes to this document.

TABLE OF CONTENT

1.	INTRODUCTION.....	3
2.	LEGAL REGULATIONS.....	3
3.	INTENDED USE	3
4.	TECHNICAL DESCRIPTION	5
5.	BELIMO ELECTRIC ACTUATORS USED IN KTS.....	8
6.	CONDITIONS OF TRANSPORT AND STORAGE	15
7.	INSTALLATION TECHNOLOGY	15
7.1.	INSTALLATION TECHNOLOGY - CEILING.....	16
7.2.	INSTALLATION TECHNOLOGY – RIGID WALL.....	17
7.2.2.	INSTALLATION USING MINERAL WOOL	19
7.3.	INSTALLATION TECHNOLOGY – FLEXIBLE WALL	20
7.4.	INSTALLATION TECHNOLOGY – HIGH WALL THICKNESS CONSTRUCTION.....	23
7.5.	INSTALLATION TECHNOLOGY – INSTALLATION AWAY FROM WALL CONSTRUCTION	24
8.	REPLACING THE THERMAL FUSE ELEMENT IN KTS-O-S	25
9.	COMMISSIONING	25
10.	PERIODIC MAINTENANCE AND SERVICING RULES	26
11.	CLASSIFICATION OF DAMPERS FOR REPAIR	27
12.	WARRANTY CONDITIONS.....	28

1. INTRODUCTION

The purpose of technical documentation is to familiarize the user with the intended use, design, operation principle, installation, periodic maintenance and operation of product.

2. LEGAL REGULATIONS

KTS-O fire dampers have **Certificate of Constancy of Performance No. 1438-CPR-0528**, issued by Scientific and Research Centre for Fire Protection – National Research Institute.

The KTS-O fire dampers are designed for application in general ventilation systems as cut-off partitions separating the fire-engulfed zone from the remaining part of the building (normally open). The purpose of these dampers is to prevent the spread of fire, heat and smoke.

The dampers are designed, manufactured and tested in accordance with the following standards: **PN-EN 15650** "Ventilation for buildings – Fire dampers" and **PN-EN 13501-3** "Fire classification of construction products and building elements – Part 3: Classification using data from fire resistance tests on products and elements used in building service installations: fire resisting ducts and fire dampers."

The effectiveness of the dampers is confirmed by tests according to **PN-EN 1366-2** "Fire resistance tests for service installations – Part 2: Fire dampers."

The KTS-O fire damper is classified as **tightness class C** (Case leakage class of the damper installed in accordance with the Technical Documentation) on the basis of tests carried out according to **PN-EN 1751** "Ventilation for buildings. Air terminal devices. Aerodynamic testing of dampers and valves."

3. INTENDED USE

The KTS-O fire dampers are classified in the following fire resistance classes and may be installed in the following building partitions:

- a. **EI 120 (ho ve i↔o) S**
 - floors, 150 [mm] in thickness or more, and a fire resistance class EI120 or higher
 - flexible walls, 100 [mm] in thickness or more and EI 120 or a higher fire resistance class (thicker, higher density, more board layers)
 - rigid walls, 100 [mm] in thickness or more, and EI120 or a higher fire resistance class (e.g. concrete walls, solid brick walls, cellular concrete block walls, hollow masonry unit walls or concrete slab walls).
- b. **EI 90 (ve i↔o) S**
 - away from rigid walls and EI90 or a higher fire resistance class (e.g. concrete walls, solid brick walls, cellular concrete block walls, hollow masonry unit walls or concrete slab walls).
- c. **EI 60 (ve i↔o) S**
 - flexible walls, 75 [mm] in thickness or more and EI60 or a higher fire resistance class (thicker, higher density, more board layers).
 - rigid walls, 75 [mm] in thickness or more and EI60 or a higher fire resistance class (e.g. concrete walls, non-hollow brick walls, cellular concrete block walls, hollow masonry unit walls or concrete slab walls).
- d. **EI 30 (ve i↔o) S**
 - flexible standard walls, 75 [mm] in thickness or more and EI30 or a higher fire resistance (thicker, greater density, more board layers).
 - rigid walls, 75 [mm] in thickness or more and EI30 or a higher fire resistance class (e.g. concrete walls, solid brick walls, cellular concrete block walls, hollow masonry unit walls or concrete slab walls).

Table 1. Table of fire resistance

Construction type	Minimum thickness of building partition mm	Fire resistance class	Sealing type
Ceiling	≥150 mm	EI 120 (h _o i↔o) S	MORTAR
Rigid wall	≥115 mm	EI 120 (v _e i↔o) S	MORTAR
	≥100 mm	EI 60 (v _e i↔o) S	MORTAR
Rigid wall	≥100 mm	EI 120 (v _e i↔o) S	MINERAL WOOL
	≥75 mm	EI 60 (v _e i↔o) S	MINERAL WOOL
	≥75 mm	EI 30 (v _e i↔o) S	MINERAL WOOL
Flexible wall	≥100 mm	EI 120 (v _e i↔o) S	MINERAL WOOL
	≥75 mm	EI 60 (v _e i↔o) S	MINERAL WOOL
	≥75 mm	EI 30 (v _e i↔o) S	MINERAL WOOL
Montage away from rigid wall	≥120 mm	EI 90 (v _e i↔o) S	MINERAL WOOL

Where:

E – fire integrity,

I – fire insulation,

S – smoke leakage,

120/90/60/30 – duration of fulfilment of E, I and S criteria, expressed in minutes,

ve – damper mounted directly in the wall,

ho – damper mounted directly in the ceiling,

i↔o – operating effectiveness criteria are fulfilled from the inside to the outside (fire inside), and from the outside to the inside (fire outside).

The KTS-O fire dampers may also be installed in buildings partitions with a lower fire resistance rating. In this case, the damper fire resistance rating is equal to the partition fire resistance rating, subject to the smoke leakage criterion.

The KTS-O fire dampers may be installed in vertical building partitions with either **horizontal or vertical rotation axis**, with any actuator position.

The KTS-O fire dampers may be installed in either inner or external buildings partitions, as also at a distance from them. In case of external wall installation, use of finishing element is required (intake or exhaust), which will protect from influence of atmospheric factors. Drive system (actuator or spring mechanism) should be installed inside facility. It is recommended to use dampers in special execution (impregnated fireproof boards, anti-corrosive steel elements).

4. TECHNICAL DESCRIPTION

The KTS-O-S dampers (with a spring mechanism) and the KTS-O-E dampers (with an electric spring return actuator) consist of a housing of a round cross-section, a moving, single-axis isolating baffle and an actuating mechanism with a release device.

The damper housing and its interacting elements are made of galvanized steel sheet. Both ends of the housing are adapted for nipple connection, allowing easy connection between the duct and the damper. There is a flange on the external side of the housing that reinforces the damper structure.

There are intumescent seals on the outer and inner surfaces of the housing, in the place of perforation, around the closed isolating baffle. Their characteristic feature is that their volume increases at high temperatures, tightly filling all leaks between the baffle and the body.

The isolating baffle of the damper is made of calcium-silicate board, and a rubber seal is installed on its perimeter, ensuring the damper integrity at ambient temperature.

The KTS-O-S damper is provided with a spring mechanism comprising, ea. an actuating spring, a manual release device and a thermal fuse with a nominal triggering temperature of $70 \pm 5[^\circ\text{C}]$ (optional $95[^\circ\text{C}]$). When the damper is being opened with a key, the actuating spring is being tensioned. The baffle is kept in the open position by the manual release device, blocked with a thermal fuse. The damper is automatically closed as a result of triggering the thermal fuse. The damage to the thermal fuse automatically rotates the isolating baffle (to the closed position). The movement of the baffle is limited by two buffers.

The KTS-O-E damper is provided with an electric spring return actuator BFL, BFN or BF series manufactured by BELIMO, and the BAT or BAE thermal fuse ($72[^\circ\text{C}]$), constituting damper's drive system supplied by the 230 V AC or 24 V AC/DC voltage. After the voltage has been supplied, the actuator rotates the baffle to the open position. The baffle is closed due to voltage loss or when the thermal fuse is activated (the return spring in the actuator closes the baffle by returning to the non-stressed position EPD). During normal operation of the system, the KTS-O-S and KTS-O-E dampers are in the open position. If a fire breaks out, the damper baffle rotates to the closed position.

The permissible flow rate in a connection duct for the KTS-O-E dampers with an actuator is 12 [m/s] and 8 [m/s] for the KTS-O-S dampers with a spring mechanism.

The range of dampers covers diameters from DN160 to DN630. The primary type series includes the following sizes: **DN160, DN200, DN250, DN315, DN355, DN400, DN450, DN500, DN560, DN630.**

The KTS-O dampers are manufactured only for the nipple connection. Depending on the actuation system used, the dampers are marked as follows:

- a. **KTS-O-S**- dampers with spring mechanism
- b. **KTS-O-E**- dampers with electric spring return actuator

BFL actuators is using for nominal diameter $\text{DN} \leq 400$.

BFN actuators is using for nominal diameter $\text{DN} > 400$.

KTS-O dampers length totals **L=375 [mm]**.

The dampers may also be fitted with limit switches indicating open or closed position of the baffle.

In a special version, resistant to aggressive environments, all components of the damper are made of stainless steel, whereas the damper baffle is impregnated with a fire-resistant board impregnation. The damper can also be manufactured as powder-coated.

The KTS-O dampers may be fitted with an inspection opening for checking the damper condition once it is installed in the ventilation system.

Table 2. KTS-O dampers weight [kg]

DN	160	200	250	315	355	400	450	500	560	630
KTS-O-S	3,5	6,1	7,7	9,6	10,9	12,3	13,8	15,3	17,2	19,3
KTS-O-E	4,7	7,3	8,9	10,8	12,1	13,5	15	16,5	18,4	20,5

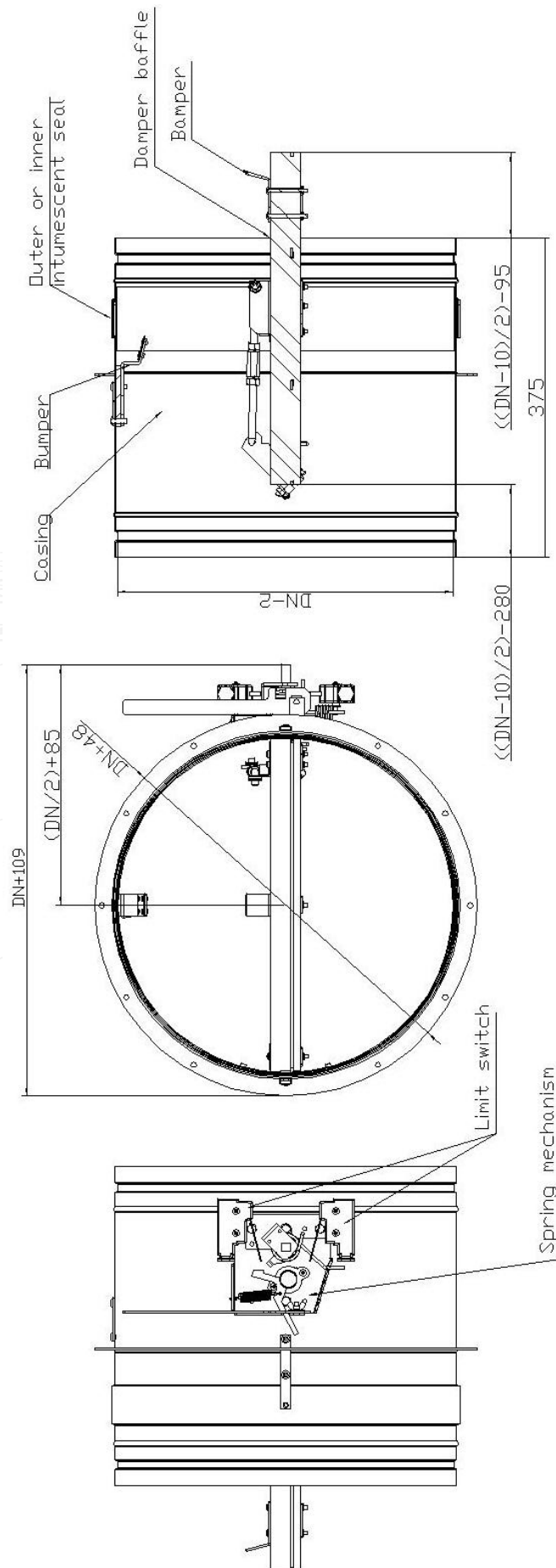

Figure 1. KTS-O-S damper, with spring mechanism

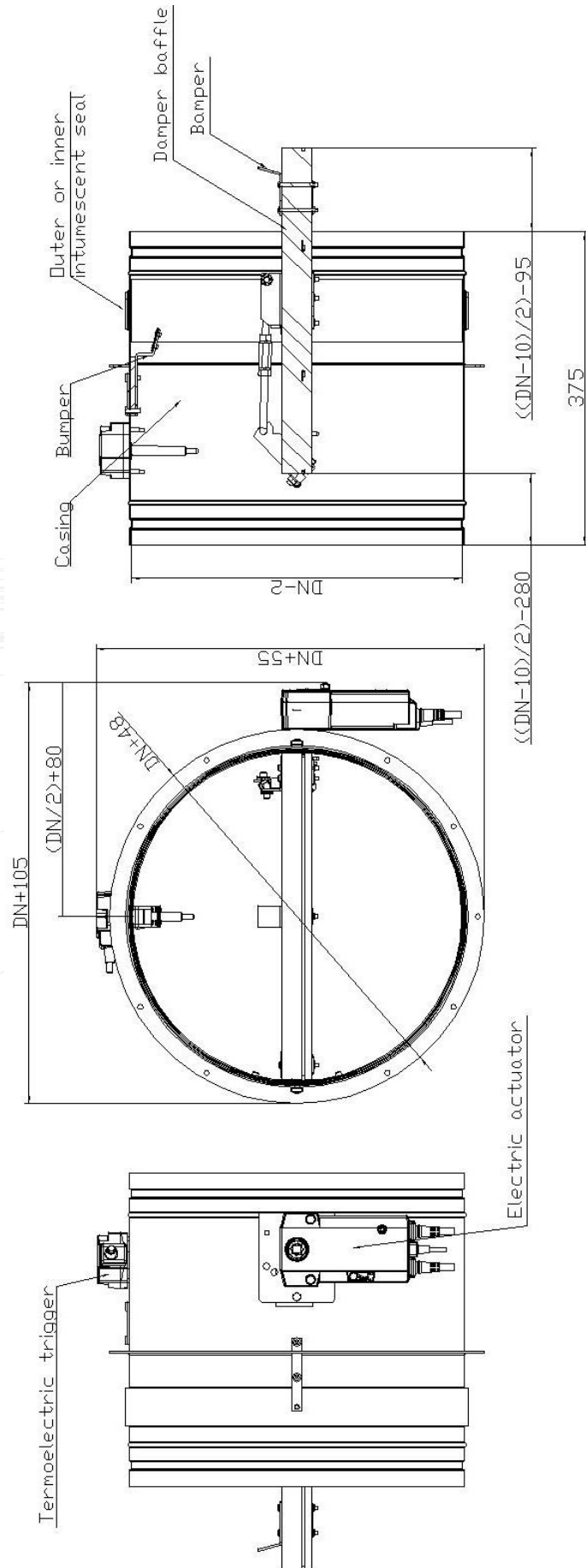

Figure 2. KTS-O-E damper with electric actuator

5. BELIMO ELECTRIC ACTUATORS USED IN KTS

Spring-return 90° actuator BFL series, combined with thermoelectric tripping device BAT:

- BFL230-T,
- BFL24-T,
- BFL24-T-ST,

where:

ST – connection plug,



Spring-return 90° actuator BFN series, combined with thermoelectric tripping device:

- BFN230-T,
- BFN24-T,
- BFN24-T-ST,

where:

ST – connection plug,



Spring-return 90° actuator BF series, combined with thermoelectric tripping device BAE:

- BF230-TN,
- BF24-TN,
- BF24-TN-ST,
- BF24-TL-TN-ST

where:

ST – connection plug,
 TL- communicative control.



Wiring diagram BFL230-T and BFN230-T

AC 230 V, open-close

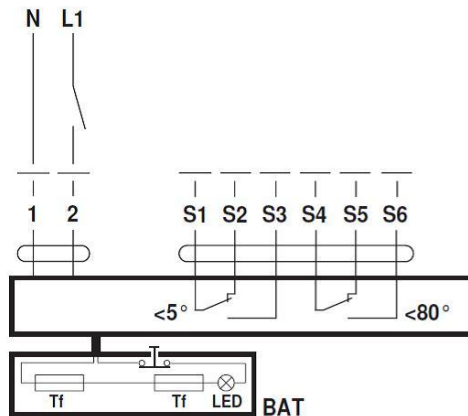
Cable colours:

 1 = blue
 2 = brown
 S1 = violet
 S2 = red
 S3 = white
 S4 = orange
 S5 = pink
 S6 = grey
 Tf: Thermal fuse (see "Technical data")

Wiring diagram BFL24-T and BFN24-T

AC/DC 24 V, open-close

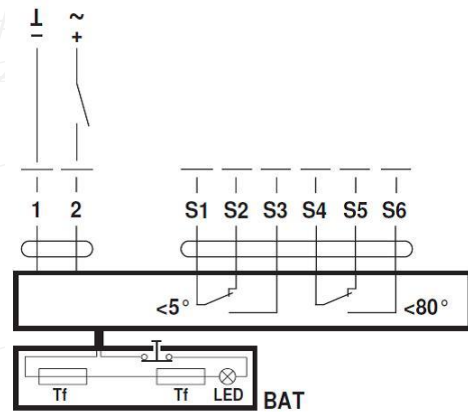
Cable colours:

 1 = black
 2 = red
 S1 = violet
 S2 = red
 S3 = white
 S4 = orange
 S5 = pink
 S6 = grey
 Tf: Thermal fuse (see "Technical data")

Wiring diagram BFL24-T-ST and BFN24-T-ST

AC/DC 24 V, open-close

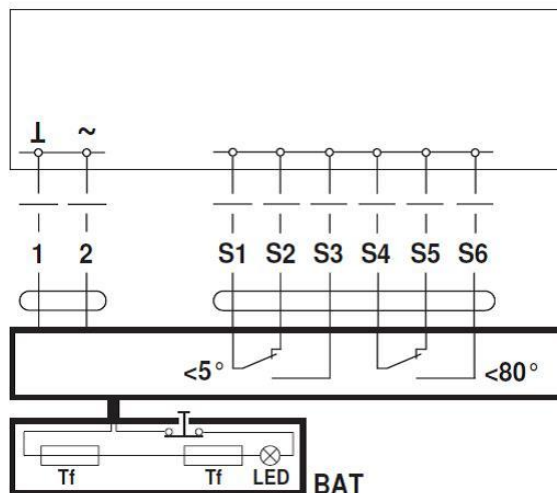

Wiring diagram BF230-TN

AC 230 V, open-close

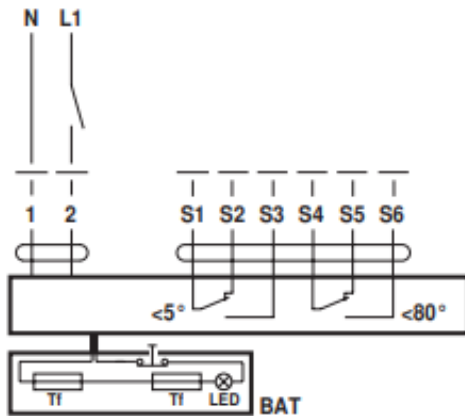
Cable colours:

 1 = blue
 2 = brown
 S1 = violet
 S2 = red
 S3 = white
 S4 = orange
 S5 = pink
 S6 = grey
 Tf: Thermal fuse (see "Technical data")

Wiring diagram BF24-TN

AC/DC 24 V, open-close

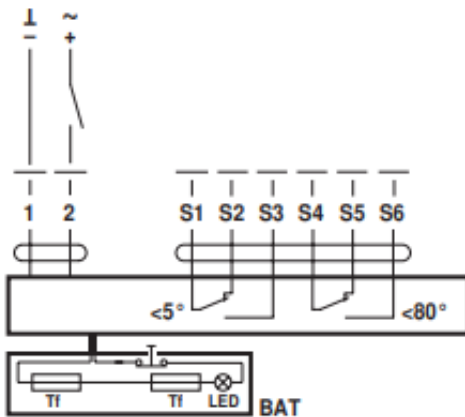
Cable colours:

 1 = black
 2 = white
 S1 = violet
 S2 = red
 S3 = white
 S4 = orange
 S5 = pink
 S6 = grey
 Tf: Thermal fuse (see "Technical data")

Wiring diagram BF24-TN-ST

AC/DC 24 V, open-close

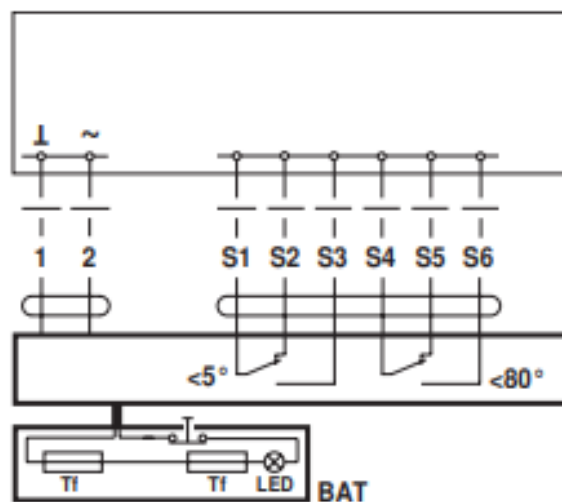

Technical data:	BFL230-T	BFN230-T
Nominal voltage	AC 230 V	AC 230 V
Nominal voltage frequency	50/60 Hz	50/60 Hz
Nominal voltage range	AC 198...264 V	AC 198...264 V
Power consumption in operation	3.5 W	5 W
Power consumption in rest position	1.1 W	2.1 W
Power consumption for wire sizing	6.5 VA	10 VA
Power consumption for wire sizing note	I _{max} 4 A @ 5 ms	I _{max} 4 A @ 5 ms
Auxiliary switch	2 x SPDT	2 x SPDT
Switching capacity auxiliary switch	1 mA...3 (0.5 inductive) A, AC 250 V	1 mA...3 (0.5 inductive) A, AC 250 V
Switching points auxiliary switch	5° / 80°	5° / 80°
Connection supply / control	Cable 1 m, 2 x 0.75 mm ² (halogen-free)	Cable 1 m, 2 x 0.75 mm ² (halogen-free)
Connection auxiliary switch	Cable 1 m, 6 x 0.75 mm ² (halogen-free)	Cable 1 m, 6 x 0.75 mm ² (halogen-free)
Cable length thermoelectric tripping device	0.5 m	1 m
Torque motor	Min. 4 Nm	Min. 9 Nm
Torque spring return	Min. 3 Nm	Min. 7 Nm
Direction of rotation motor	Can be selected by mounting L/R	Can be selected by mounting L/R
Manual override	With position stop	With position stop
Angle of rotation	Max. 95°	Max. 95°
Running time motor	<60 s / 90°	<60 s / 90°
Running time spring-return	20 s @ -10...55°C / <60 s @ -30...-10°C	20 s @ -10...55°C / <60 s @ -30...-10°C
Sound power level motor	<43 dB(A)	<55 dB(A)
Sound power level spring-return	<62 dB(A)	<67 dB(A)
Spindle driver	Form fit 12x12 mm, Continuous hollow shaft	Form fit 12x12 mm, Continuous hollow shaft
Position indication	Mechanically, with pointer	Mechanically, with pointer
Service life	Min. 60,000 safety positions	Min. 60,000 safety positions
Response temperature thermal fuse	Duct outside temperature 72°C Duct inside temperature 72°C	Duct outside temperature 72°C Duct inside temperature 72°C
Protection class IEC/EN	II Protective insulated	II Protective insulated
Protection class auxiliary switch IEC/EN	II Protective insulated	II Protective insulated
Degree of protection IEC/EN	IP54 in all mounting positions	IP54 in all mounting positions
EMC	CE according to 2014/30/EU	CE according to 2014/30/EU
Low voltage directive	CE according to 2014/35/EU	CE according to 2014/35/EU
Certification IEC/EN	IEC/EN 60730-1 and IEC/EN 60730-2-14	IEC/EN 60730-1 and IEC/EN 60730-2-14
Mode of operation	Type 1.AA.B	Type 1.AA.B
Rated impulse voltage supply / control	4 kV	4 kV
Control pollution degree	3	3
Ambient temperature normal operation	-30...55°C	-30...55°C
Ambient temperature safety operation	The safety position will be attained up to max. 75°C	The safety position will be attained up to max. 75°C
Non-operating temperature	-40...55°C	-40...55°C
Ambient humidity	95% r.h., non-condensing	95% r.h., non-condensing
Maintenance	Maintenance-free	Maintenance-free
Weight	1.2 kg	1.5 kg

Technical data:	BFL24-T(-ST)	BFN24-T(-ST)
Nominal voltage	AC/DC 24 V	AC/DC 24 V
Nominal voltage frequency	50/60 Hz	50/60 Hz
Nominal voltage range	AC 19.2...28.8 V / DC 21.6...28.8 V	AC 19.2...28.8 V / DC 21.6...28.8 V
Power consumption in operation	2.5 W	4 W
Power consumption in rest position	0.8 W	1.4 W
Power consumption for wire sizing	4 VA	6 VA
Power consumption for wire sizing note	I _{max} 8.3 A @ 5 ms	I _{max} 8.3 A @ 5 ms
Auxiliary switch	2 x SPDT	2 x SPDT
Switching capacity auxiliary switch	1 mA...3 (0.5 inductive) A, AC 250 V	1 mA...3 (0.5 inductive) A, AC 250 V
Switching points auxiliary switch	5° / 80°	5° / 80°
Connection supply / control	Cable 1 m, 2 x 0.75 mm ² (halogen-free)	Cable 1 m, 2 x 0.75 mm ² (halogen-free)
Connection auxiliary switch	Cable 1 m, 6 x 0.75 mm ² (halogen-free)	Cable 1 m, 6 x 0.75 mm ² (halogen-free)
Cable length thermoelectric tripping device	0.5 m	1 m
Torque motor	Min. 4 Nm	Min. 9 Nm
Torque spring return	Min. 3 Nm	Min. 7 Nm
Direction of rotation motor	Can be selected by mounting L/R	Can be selected by mounting L/R
Manual override	With position stop	With position stop
Angle of rotation	Max. 95°	Max. 95°
Running time motor	<60 s / 90°	<60 s / 90°
Running time spring-return	20 s @ -10...55°C / <60 s @ -30...-10°C	20 s @ -10...55°C / <60 s @ -30...-10°C
Sound power level motor	<43 dB(A)	<55 dB(A)
Sound power level spring-return	<62 dB(A)	<67 dB(A)
Spindle driver	Form fit 12x12 mm, Continuous hollow shaft	Form fit 12x12 mm, Continuous hollow shaft
Position indication	Mechanically, with pointer	Mechanically, with pointer
Service life	Min. 60,000 safety positions	Min. 60,000 safety positions
Response temperature thermal fuse	Duct outside temperature 72°C Duct inside temperature 72°C	Duct outside temperature 72°C Duct inside temperature 72°C
Protection class IEC/EN	III Safety extra-low voltage	III Safety extra-low voltage
Protection class auxiliary switch IEC/EN	II Protective insulated	II Protective insulated
Degree of protection IEC/EN	IP54 in all mounting positions	IP54 in all mounting positions
EMC	CE according to 2014/30/EU	CE according to 2014/30/EU
Low voltage directive	CE according to 2014/35/EU	CE according to 2014/35/EU
Certification IEC/EN	IEC/EN 60730-1 and IEC/EN 60730-2-14	IEC/EN 60730-1 and IEC/EN 60730-2-14
Mode of operation	Type 1.AA.B	Type 1.AA.B
Rated impulse voltage supply / control	0.8 kV	0.8 kV
Control pollution degree	3	3
Ambient temperature normal operation	-30...55°C	-30...55°C
Ambient temperature safety operation	The safety position will be attained up to max. 75°C	The safety position will be attained up to max. 75°C
Non-operating temperature	-40...55°C	-40...55°C
Ambient humidity	95% r.h., non-condensing	95% r.h., non-condensing
Maintenance	Maintenance-free	Maintenance-free
Weight	1.2 kg	1.5 kg

Technical data: BF230-TN

Electrical data	Nominal voltage	AC 230 V
	Nominal voltage frequency	50/60 Hz
	Nominal voltage range	AC 198...264 V
	Power consumption in operation	8.5 W
	Power consumption in rest position	3 W
	Power consumption for wire sizing	11 VA
	Power consumption for wire sizing note	I _{max} 0.5 A @ 5 ms
	Auxiliary switch	2 x SPDT
	Switching capacity auxiliary switch	1 mA...6 A (3 A inductive), DC 5 V...AC 250 V (II reinforced insulation)
	Switching points auxiliary switch	5° / 80°
	Connection supply / control	Cable 1 m, 2 x 0.75 mm ² (halogen-free)
	Connection auxiliary switch	Cable 1 m, 6 x 0.75 mm ² (halogen-free)
Functional data	Torque motor	18 Nm
	Torque fail-safe	12 Nm
	Direction of rotation motor	Can be selected by mounting L/R
	Manual override	with position stop
	Angle of rotation	Max. 95°
	Running time motor	<120 s / 90°
	Running time fail-safe	16 s @ -10...55°C / <60 s @ -30...-10°C
	Running time fail-safe note	@ -10...55°C / <60 s @ -30...-10°C
	Sound power level, motor	45 dB(A)
	Sound power level, fail-safe	63 dB(A)
	Mechanical interface	Form fit 12x12 mm, Non-continuous hollow shaft
	Position indication	Mechanically, with pointer
Service life	Min. 60'000 safety positions	
Safety	Protection class IEC/EN	II reinforced insulation
	Protection class auxiliary switch IEC/EN	II reinforced insulation
	Degree of protection IEC/EN	IP54 in all mounting positions
	EMC	CE according to 2014/30/EU
	Low voltage directive	CE according to 2014/35/EU
	Certification IEC/EN	IEC/EN 60730-1 and IEC/EN 60730-2-14
	Mode of operation	Type 1.AA.B
	Rated impulse voltage supply / control	4 kV
	Control pollution degree	3
	Ambient temperature normal operation	-30...50°C
	Ambient temperature safety operation	The safety position will be attained up to max. 75°C
	Storage temperature	-40...50°C
Ambient humidity	Max. 95% r.H., non-condensing	
Servicing	maintenance-free	
Weight	Weight	3.1 kg

Technical data:
BF24-TN

Electrical data	Nominal voltage	AC/DC 24 V
	Nominal voltage frequency	50/60 Hz
	Nominal voltage range	AC 19.2...28.8 V / DC 21.6...28.8 V
	Power consumption in operation	7 W
	Power consumption in rest position	2 W
	Power consumption for wire sizing	10 VA
	Power consumption for wire sizing note	I_{max} 8.3 A @ 5 ms
	Auxiliary switch	2 x SPDT
	Switching capacity auxiliary switch	1 mA...6 A (3 A inductive), DC 5 V...AC 250 V (II reinforced insulation)
	Switching points auxiliary switch	5° / 80°
Connection supply / control	Cable 1 m, 2 x 0.75 mm ² (halogen-free)	
Connection auxiliary switch	Cable 1 m, 6 x 0.75 mm ² (halogen-free)	
Functional data	Torque motor	18 Nm
	Torque fail-safe	12 Nm
	Direction of rotation motor	Can be selected by mounting L/R
	Manual override	with position stop
	Angle of rotation	Max. 95°
	Running time motor	<120 s / 90°
	Running time fail-safe	16 s $t_{amb} = 20^{\circ}C$
	Running time fail-safe note	$t_{amb} = 20^{\circ}C$
	Sound power level, motor	45 dB(A)
	Sound power level, fail-safe	63 dB(A)
	Mechanical interface	Form fit 12x12 mm, Non-continuous hollow shaft
	Position indication	Mechanically, with pointer
	Service life	Min. 60'000 safety positions
Safety	Protection class IEC/EN	III Safety Extra-Low Voltage (SELV)
	Protection class auxiliary switch IEC/EN	II reinforced insulation
	Degree of protection IEC/EN	IP54 in all mounting positions
	EMC	CE according to 2014/30/EU
	Low voltage directive	CE according to 2014/35/EU
	Certification IEC/EN	IEC/EN 60730-1 and IEC/EN 60730-2-14
	Mode of operation	Type 1.AA.B
	Rated impulse voltage supply / control	0.8 kV
	Control pollution degree	3
	Ambient temperature normal operation	-30...50°C
	Ambient temperature safety operation	The safety position will be attained up to max. 75°C
	Storage temperature	-40...50°C
	Ambient humidity	Max. 95% r.H., non-condensing
	Servicing	maintenance-free
	Weight	Weight

6. CONDITIONS OF TRANSPORT AND STORAGE

Fire dampers KTS-O should be stored in cardboard boxes and/or on pallets. KTS-O should have a pre-protected actuator cardboard box. Fire dampers should be stored indoors, providing protection against atmospheric agents, at a minimum temperature of +5 °C.

Do not allow mechanical damage of damper, that may be caused e.g. blows or dropping. During transport, the dampers should be packed in cartons and / or placed on pallets and protected against changing position and weather conditions.

After each transport, visual inspection of each fire damper must be carried out.

7. INSTALLATION TECHNOLOGY

Before installing the fire dampers, make sure that there are no damage, during transport or storage, that could block the baffle.

Check that the baffle can be opened and closed (full opening and closing position). To open fire dampers KTS-O-S use the actuator key.

The opening and closing must proceed smoothly (not stepwise).

Do not pull by baffle to open or close fire damper, it may cause permanent damage, not covered by the warranty.

During KTS-O-S damper test, to opening use a key, mounted on housing.

Before installing, secure the fire damper, by dust and dirt, using a foil or other screening material. It can prevent components of fire damper by damage.

Dampers to preserve of the declared resistance, insulation and smoke leakage EIS120, EIS90, EIS60, EIS30, should be installed on wall, which was classified as EIS120, EIS90, EIS60, EIS30.

It is allowed to install KTS-O dampers in wall with other fire-resistance, should be remembered that fire-resistance in this situation is resistance of lowest classified (in this regard) element in this system.

Ducts made of flammable and non-flammable materials can be connected to the damper. Ducts should be installed that they cannot load the damper during fire. Ducts lengthening during fire can be compensated by support and knee. ATTENTION: Distance between fire dampers or fire damper and construction elements must be compatible with standard 1366-2:

- c. min. 200 mm between fire damper, which are installed in different ventilating ducts, and between flaps and openings in the building partition;
- d. min. 75 mm between fire damper and construction element (wall/ceiling).

7.1. INSTALLATION TECHNOLOGY - CEILING

- Make an opening in the ceiling with the 70 [mm] (acceptable 60 ÷ 100 mm) greater than the nominal dimensions of the damper: DN+70.
- Put the damper into the installation opening and support or suspend it in order to maintain correct position of the damper i.e. the damper embossing must be on boundary of the building, and installation opening axis must coincide with fire damper axis.
- After setting the fire damper as described, mounting the mounting brackets, fill the gap between the fire damper and the ceiling with cement, cement-lime mortar or concrete.
- After drying of the mortar (approx. 48 hours), remove used supports or suspension, check the fire damper correct operation and leave it in fully open position.

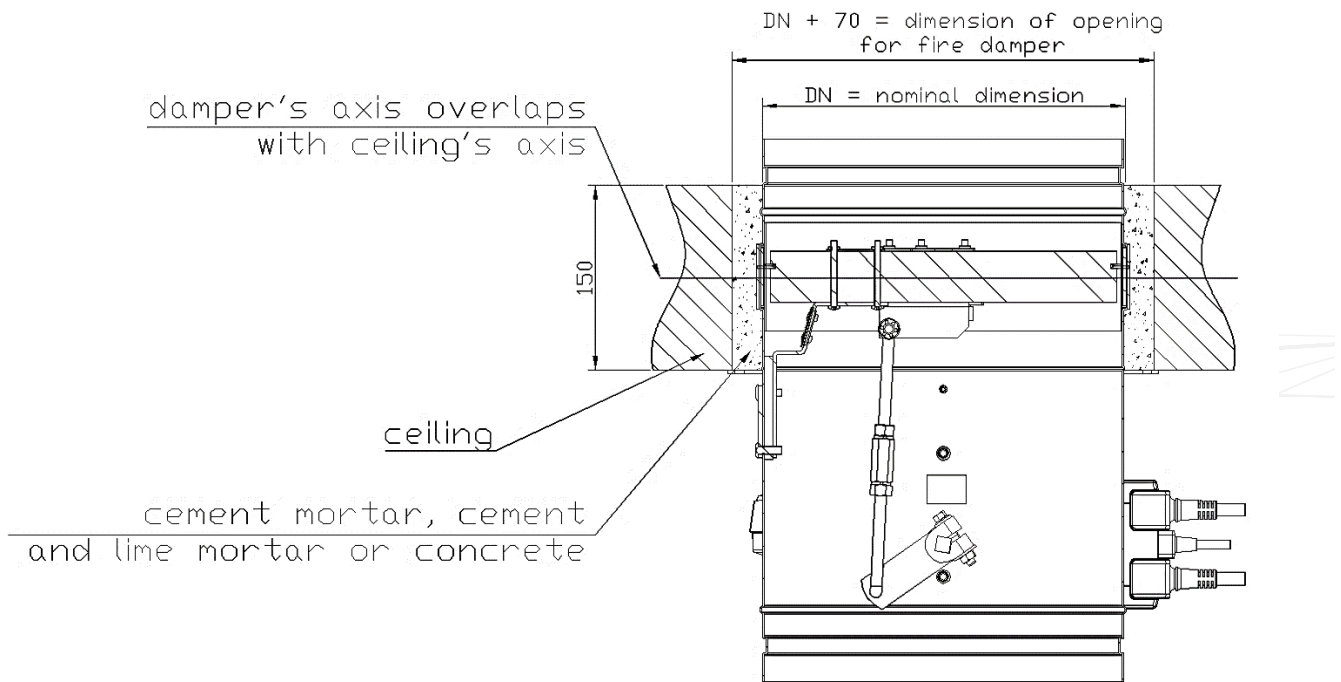

Figure 3. Installation method of fire dampers KTS-O in ceiling

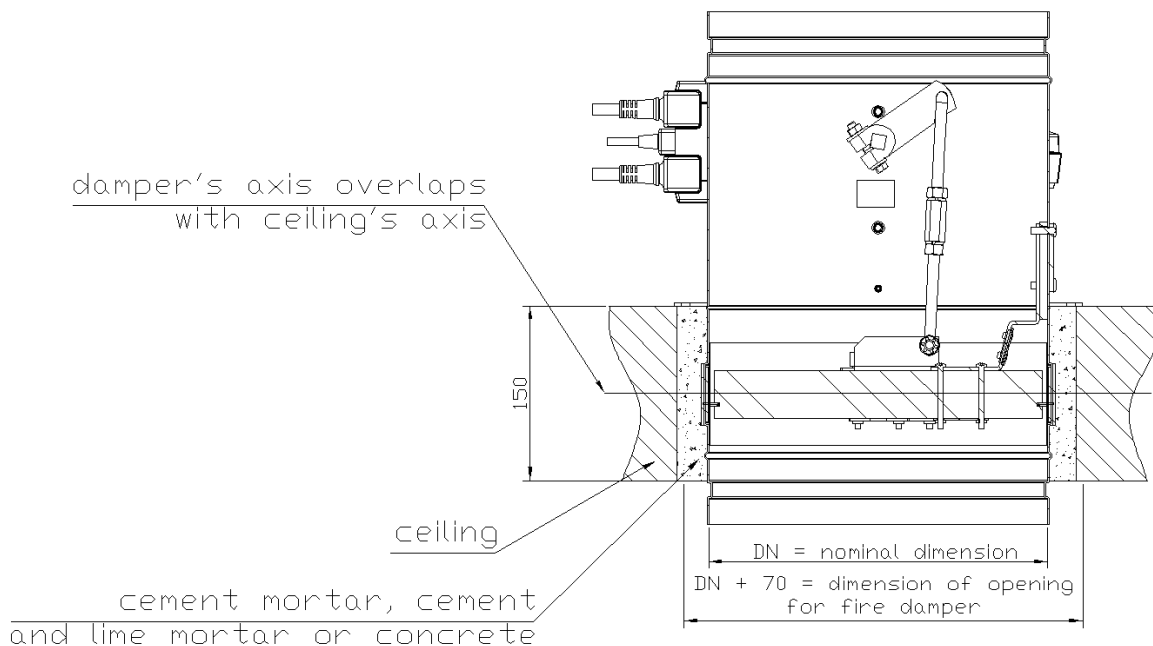

Figure 4. Installation method of fire dampers KTS-O in ceiling

7.2. INSTALLATION TECHNOLOGY – RIGID WALL

7.2.1. INSTALLATION USING MORTAR

- Make an opening in the wall with the 70 mm (acceptable $60 \div 100$ mm) greater than the nominal dimensions of the fire damper: $DN+70$.
- Put the damper into the installation opening and support or suspend it in order to maintain correct position of the damper i.e. the damper embossing must be on boundary of the building, and installation opening axis must coincide with fire damper axis.
- After setting the fire damper as described, fill the gap between the fire damper and the wall with cement, cement-lime mortar or concrete.
- After drying of the mortar (approx. 48 hours), remove used supports or suspensions, check the fire damper correct operation and leave it in fully open position.

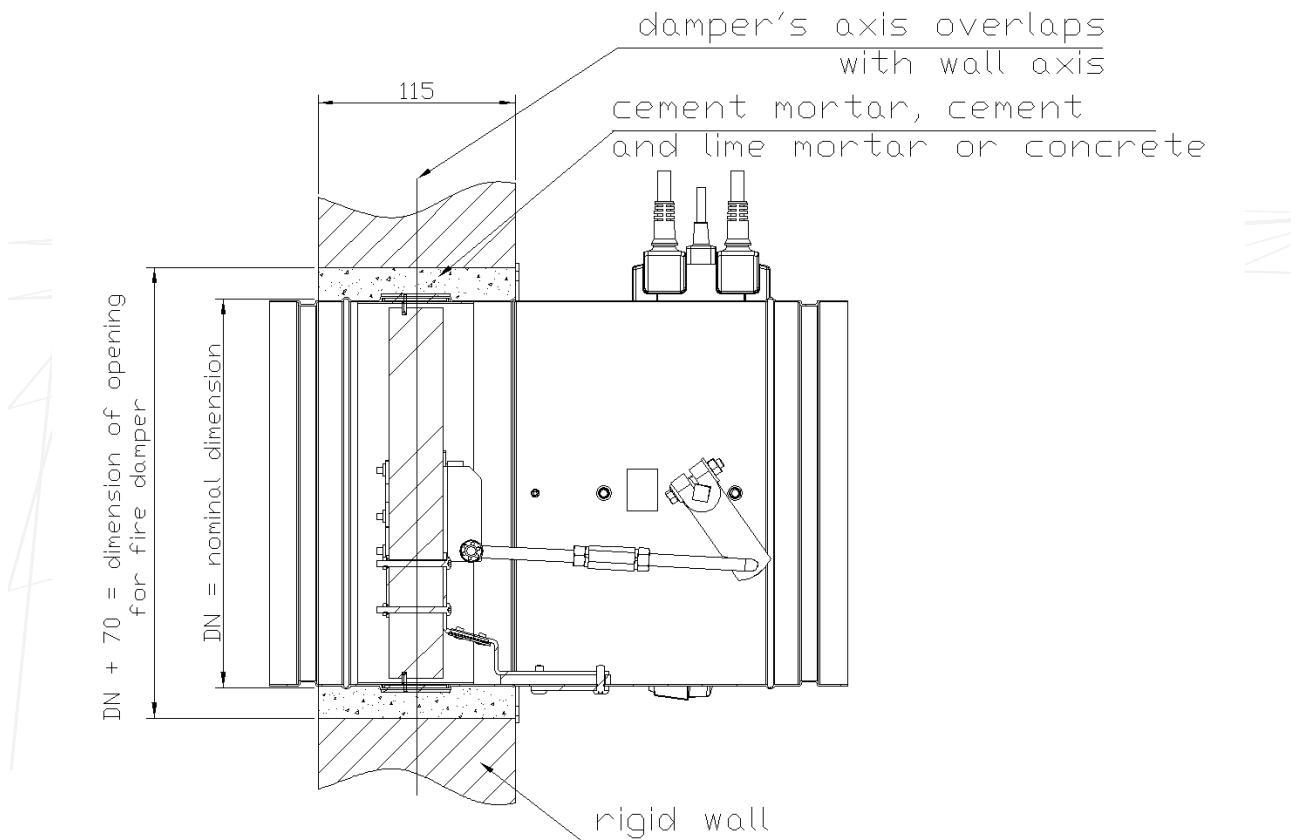

Figure 5. Installation of the KTS-O in a wall at least 115 mm thick using mortar

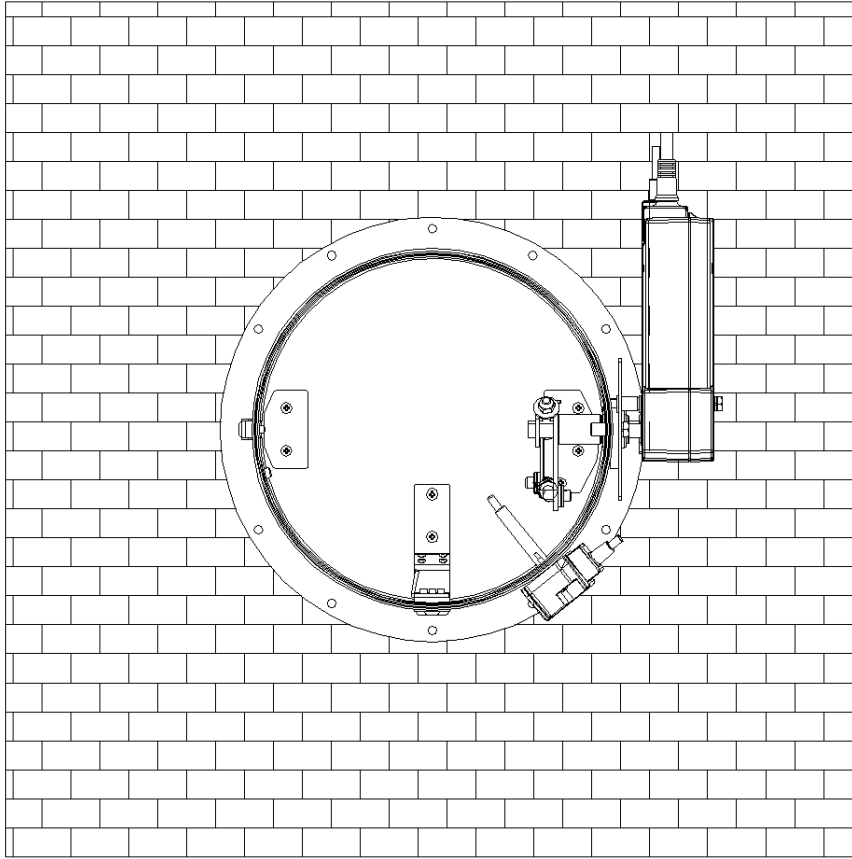

Figure 6. Installation of KTS-O in rigid wall construction with horizontal axis of rotation of the damper.

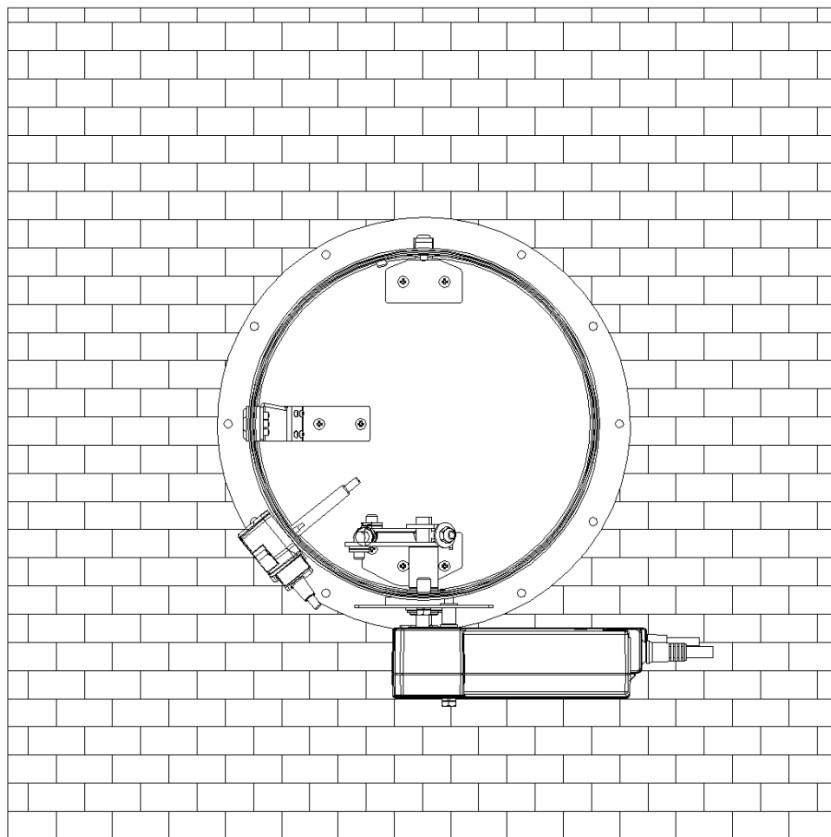

Figure 7. Installation of KTS-O in rigid wall construction with vertical axis of rotation of the damper.

7.2.2. INSTALLATION USING MINERAL WOOL

- Make an opening in the wall with the 70 mm (acceptable $60 \div 100$ mm) greater than the nominal dimensions of the fire damper: $B=DN+70$ and $H=DN+70$.
- Put the closed fire damper into the installation opening and support or suspend, in this way that an axis of the fire baffle matches the axis of the wall, and ensure a concentricity of fire damper and installation opening.
- After setting the fire damper as described, fill the gap between the fire damper and the wall with non-flammable mineral wool of high density, 100 kg/m^3 or more.
- Seal the place of filling with mineral wool using the sealing compounds Hilti Firestop Coating CP 673, Promastop-CC, Promaseal-Mastic or Soudal Firesilicone B1 FR.
- Mount collar, both side of wall, made of GKF boards, 12,5 mm thick measuring $B \times H=DN+370 \times DN+370$ using screws (with a cut hole for the damper). For easy assembly, the collar can be made of two parts.
- After mounting the collar, remove the supports or suspension, check the fire damper correct operation and leave it in open position.

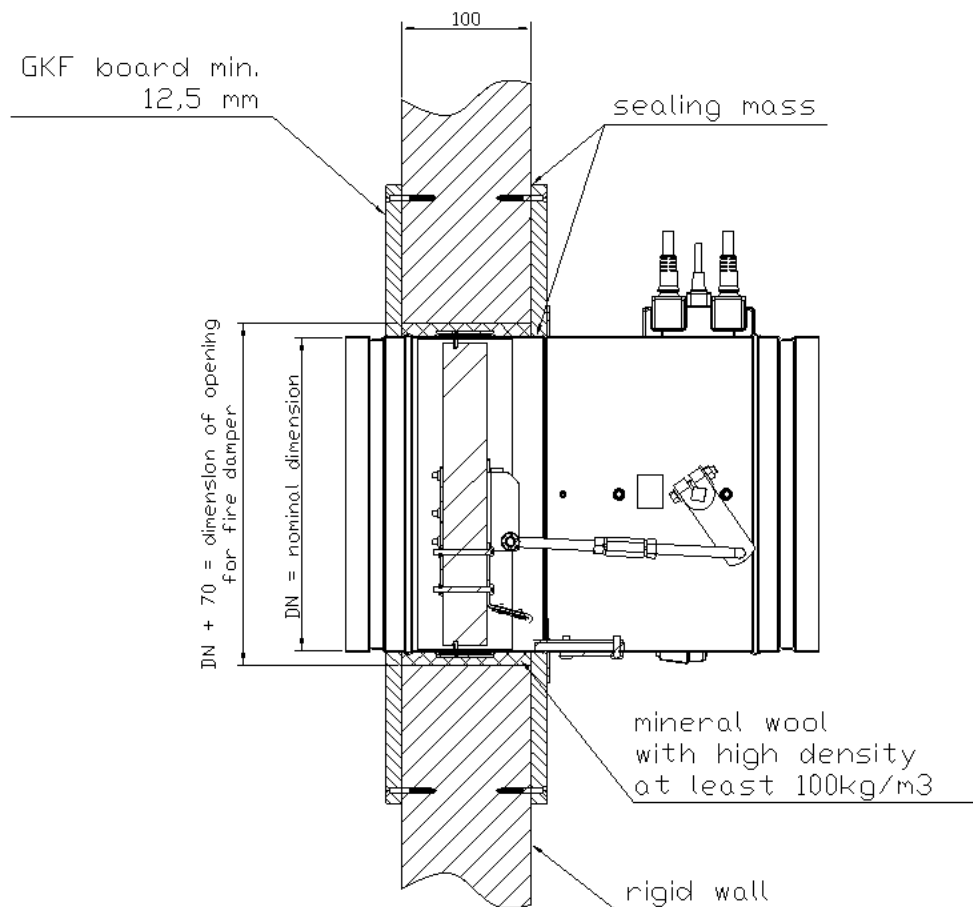

Figure 8. *Installation of the KTS-O in a wall at least 115 mm thick using mineral wool*

7.3. INSTALLATION TECHNOLOGY – FLEXIBLE WALL

- Make an opening in the wall with the 70 mm (acceptable $60 \div 100$ mm) greater than the nominal dimensions of the fire damper: $B=DN+70$ and $H=DN+70$.
- Put the damper into the installation opening and support or suspend it in order to maintain correct position of the damper i.e. the damper embossing must be on boundary of the building, and installation opening axis must coincide with fire damper axis.
- After setting the fire damper as described, fill the gap between the fire damper and the wall with non-flammable mineral wool of high density, 100 kg/m^3 or more.
- Seal the place of filling with mineral wool using the sealing compounds: Hilti Firestop Coating CP 673, Promastop-CC, Promaseal-Mastic or Soudal Firesilicone B1 FR.
- Mount collar, both side of wall, made of GKF boards, 12,5 mm thick and $DN+350$ mm wide, using screws (with the hole for the damper cutted out). For easy assembly, the collar can be made of two parts.
- After mounting the collar, remove the supports or suspensions, check the fire damper correct operation and leave it in open position.

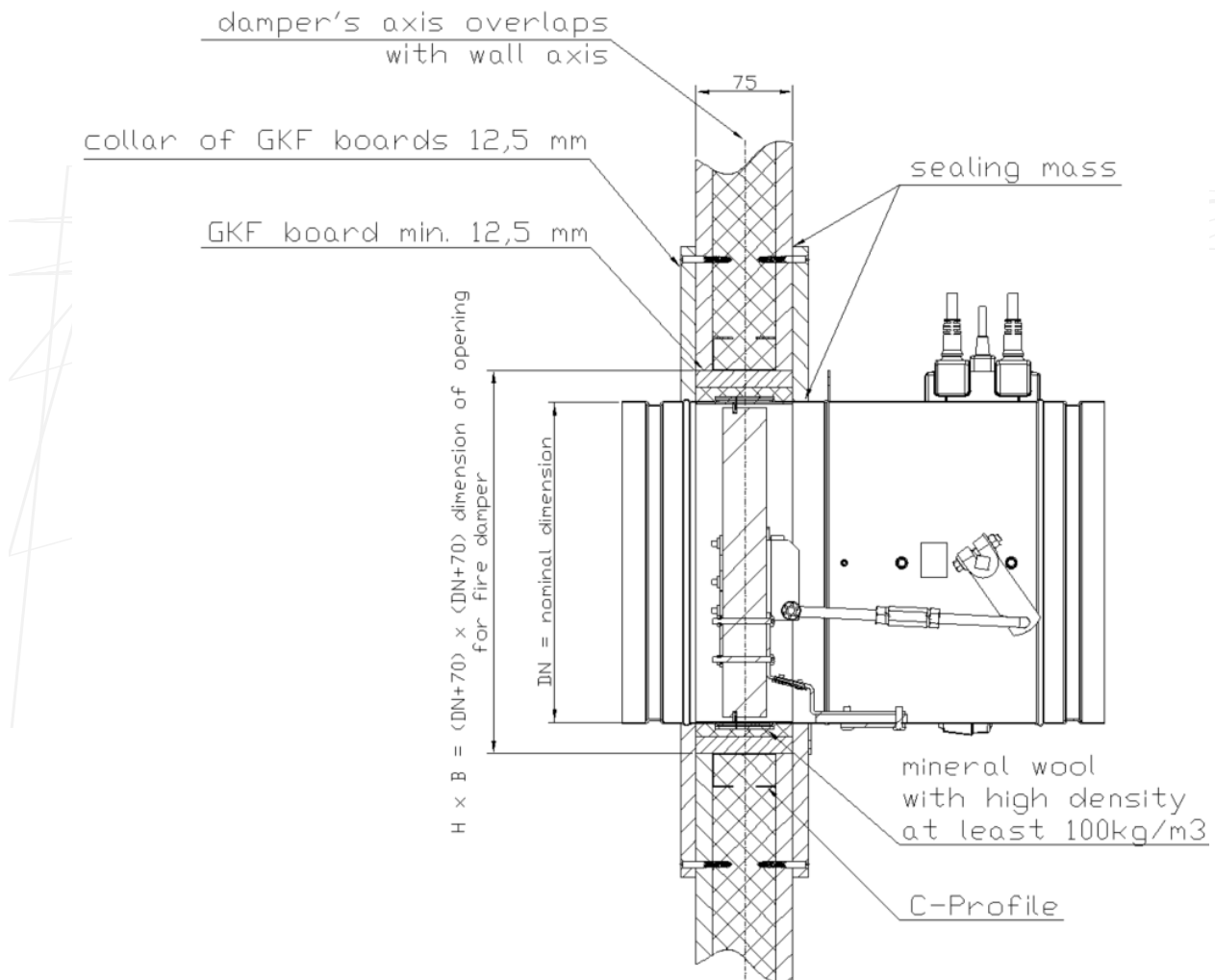

Figure 9. Installation of KTS-O in flexible wall construction with 75 mm thickness

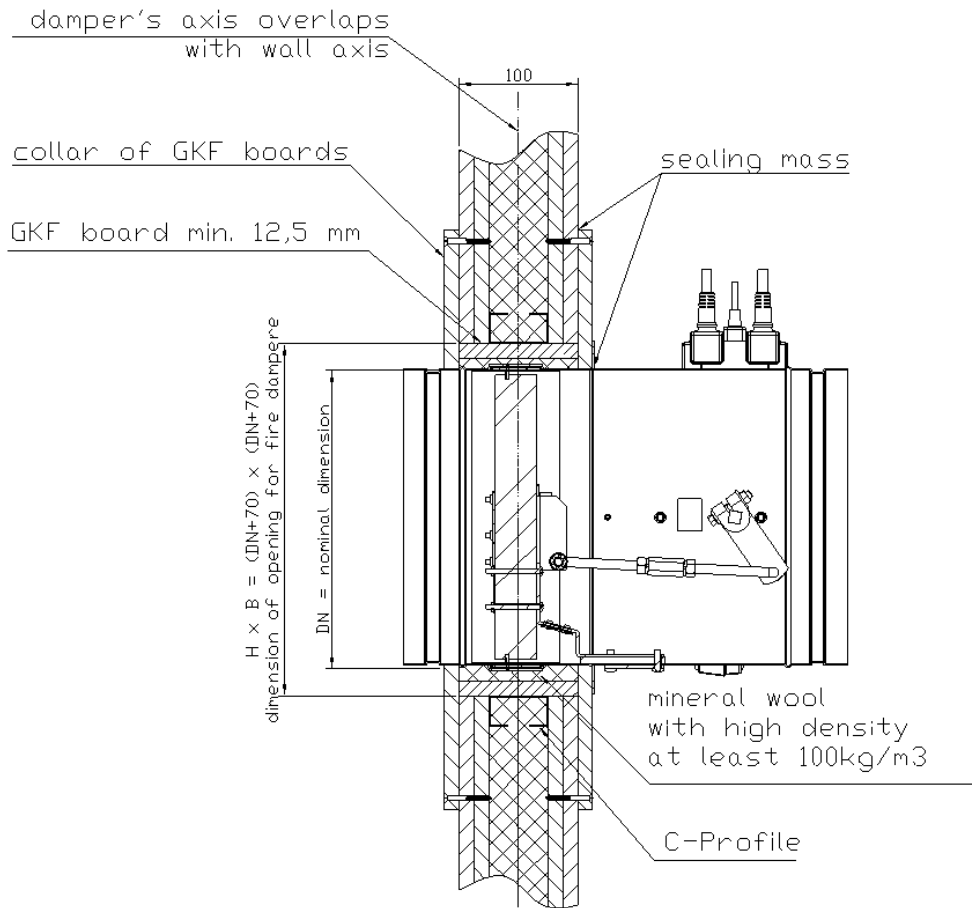

Figure 10. Installation method of fire dampers KTS-O in flexible wall with 100 mm thickness

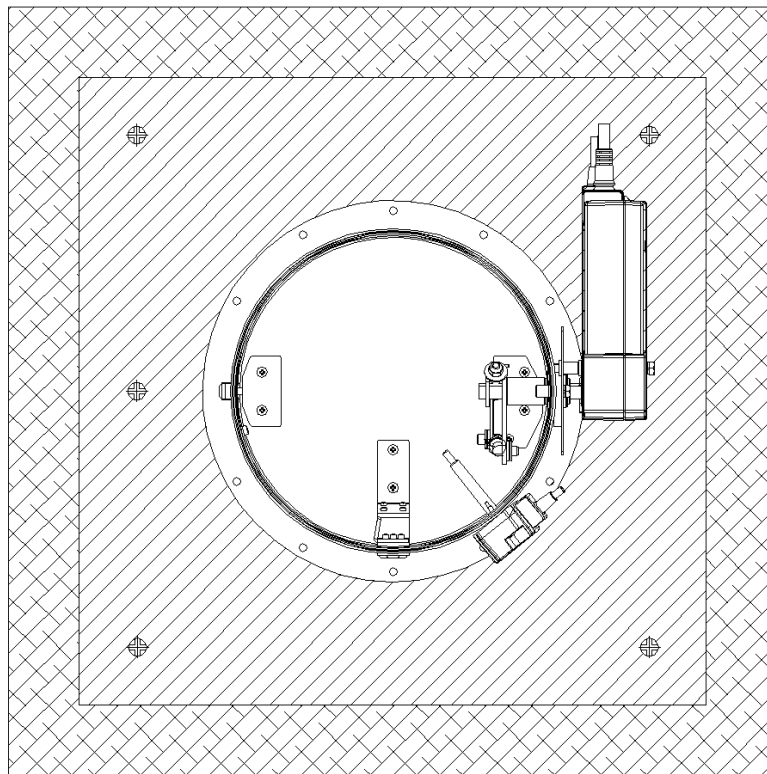

Figure 11. Installation method of fire dampers KTS-O in flexible wall with horizontal rotation axis of baffle

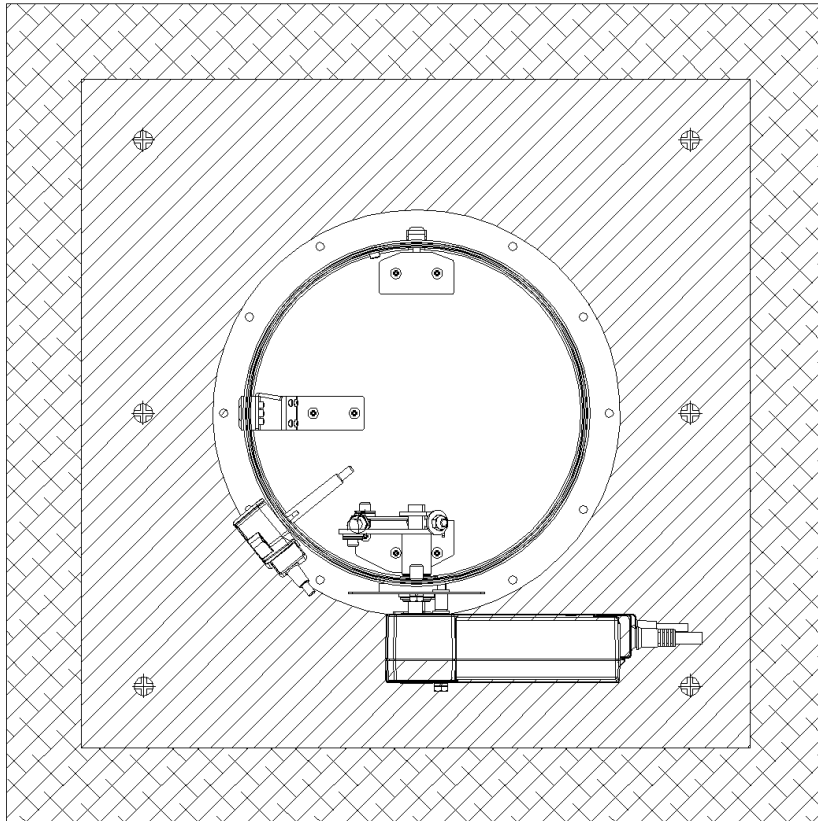

Figure 12. Installation method of fire dampers KTS-O in flexible wall with vertical rotation axis of baffle

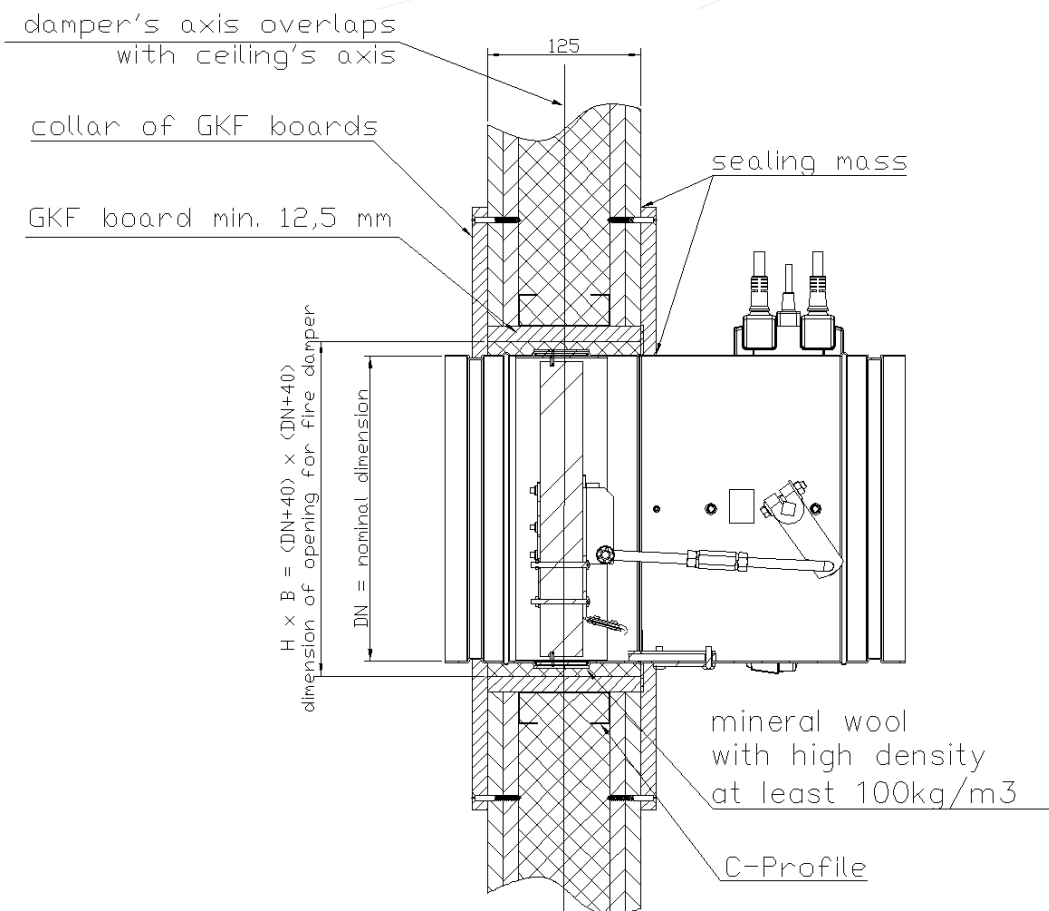

Figure 13. Installation method of fire dampers KTS-O in flexible wall with 125 [mm] thickness

7.4. INSTALLATION TECHNOLOGY – HIGH WALL THICKNESS CONSTRUCTION

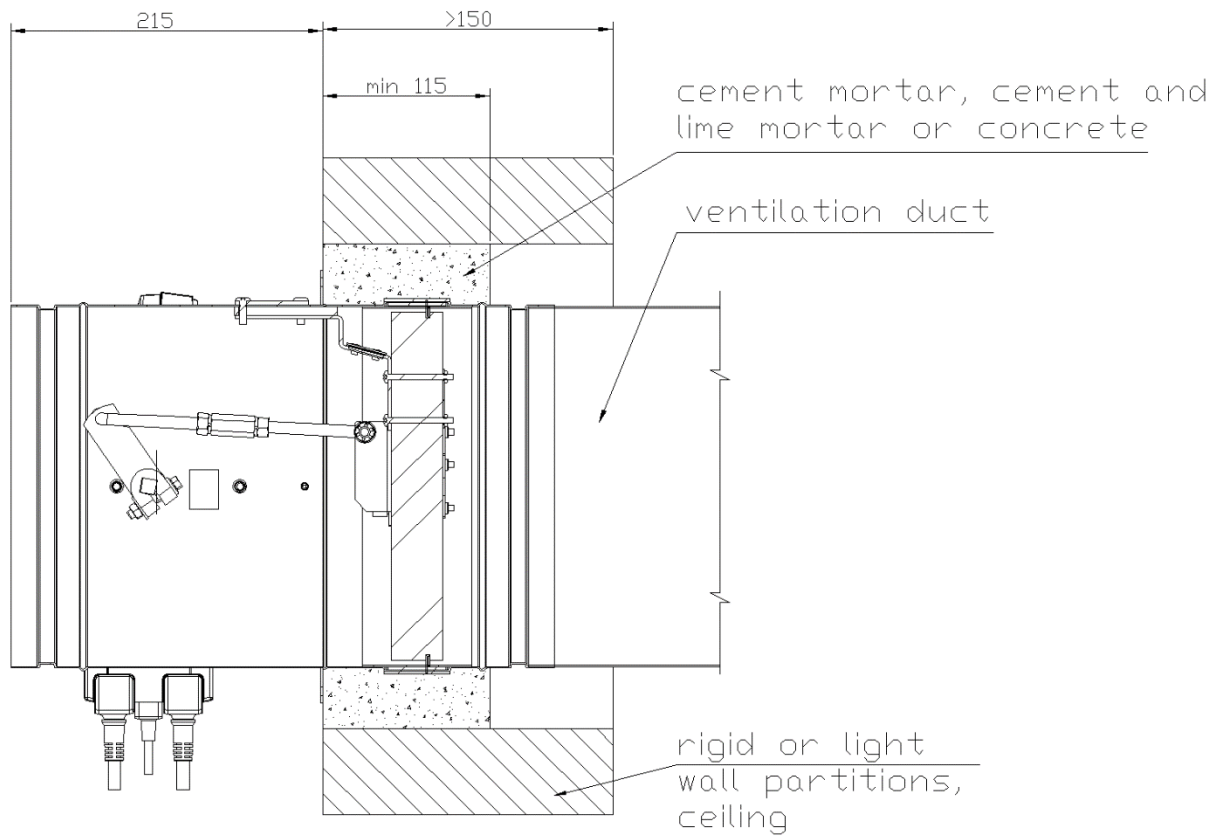

Figure 14. Installation method of fire dampers KTS-O in high wall thickness constructions

In rigid and flexible wall construction and in ceiling with thickness less or equal to 150 mm, KTS-O fire dampers are mounted in such a way that the damper installation limit, i.e. 52 mm, is maintained and the damper embossing must be on boundary of the building.

Whereas in case of walls and ceilings with thickness higher than 150 mm: the KTS-O fire dampers are mounted in such a way, that the damper installation limit i.e. 215 mm, is maintained and the damper flange must be on boundary of the building (as in figure 14).

7.5. INSTALLATION TECHNOLOGY – INSTALLATION AWAY FROM WALL CONSTRUCTION

- Make an opening in the wall with the dimensions 100 mm greater than the nominal dimensions of the fire damper, i.e. DN+100.
- Push the ventilation duct into the installation opening and support or suspend it so that the channel and opening alignment are maintained.
- Mount the damper to ventilation duct, additionally support or suspend it.
- On the mineral wool coverage section, apply 1 mm PROMASTOP CC (made by PROMAT) layer.
- The PROMASTOP CC layer has to be applied on fire barrier in the place where the wool was sealed on both sides, with a size about DN + 300.
- Wrap the ventilation duct and the damper at the appropriate length of mineral wool with high density at least 100 kg/m³.
- When the mineral wool is mounted, check correct functionality of the damper, then leave it in the open position.

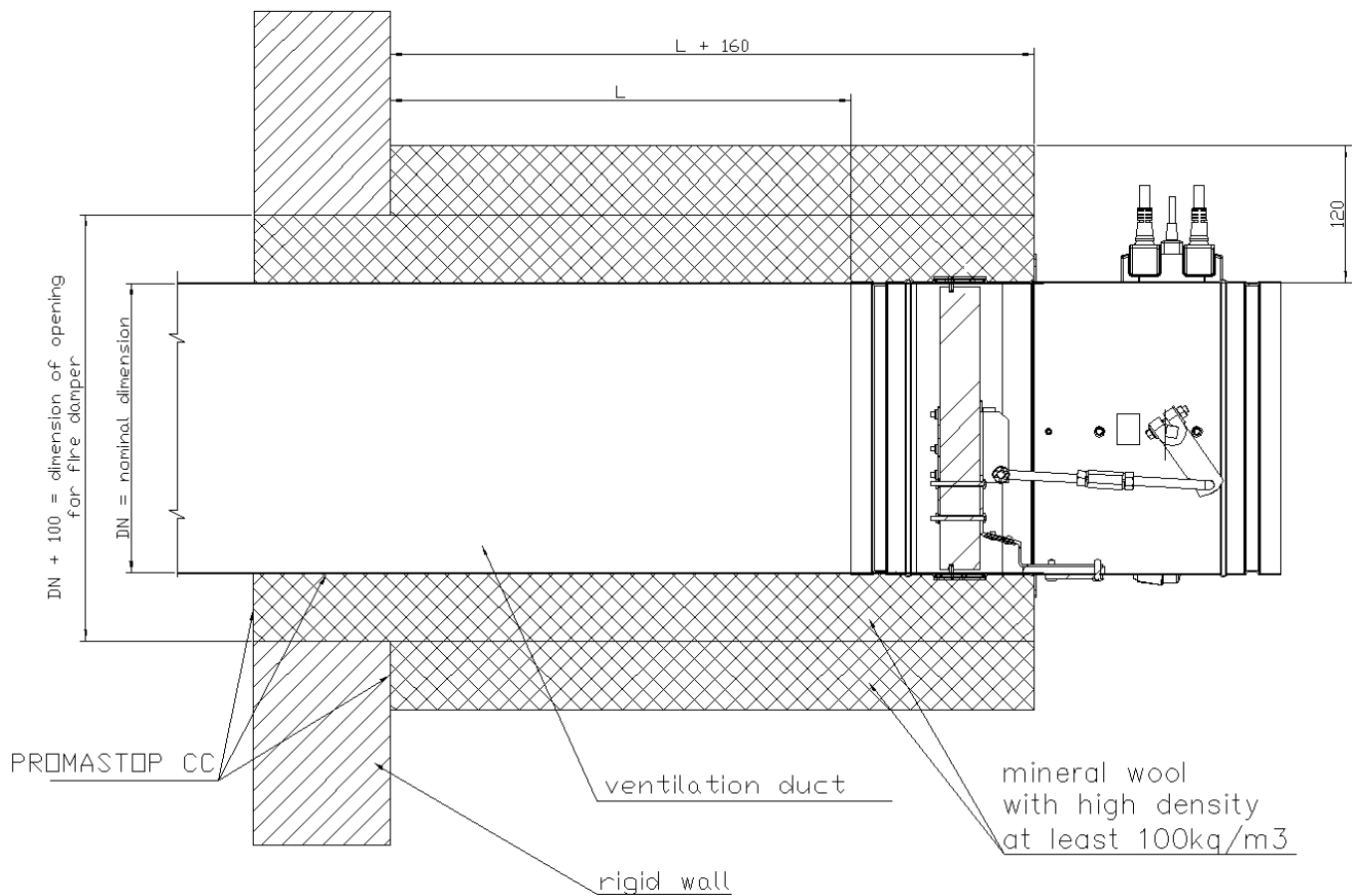

Figure 15. Installation method of fire dampers KTS-O away from wall constructions

8. REPLACING THE THERMAL FUSE ELEMENT IN KTS-O-S

Exchange must be performed on the closed position.
To replace the thermal fuse element:

- Release the spring **7** from the spring mechanism plate **1**.
- Unscrew the bolt **14** and pull out the entire thermal fuse element. The assembly of these elements consists of a thermal fuse element **16**, hook **6**, console **5**, washer **7**, release spring **9**, nut M8 **12**, round nut **8**, thermal fuse plate **13**. To replace the thermal fuse, press the hook **6** towards to the nut and put into console. When you put the thermal fuse, release the hook and push the lever of hand mechanism.
- Install the assembly of thermal fuse with the bolt **14**.
- Pull the spring onto spring mechanism plate **1**.
- Open the fire damper and check that it opens and closes correctly after push the hand release lever **11**.

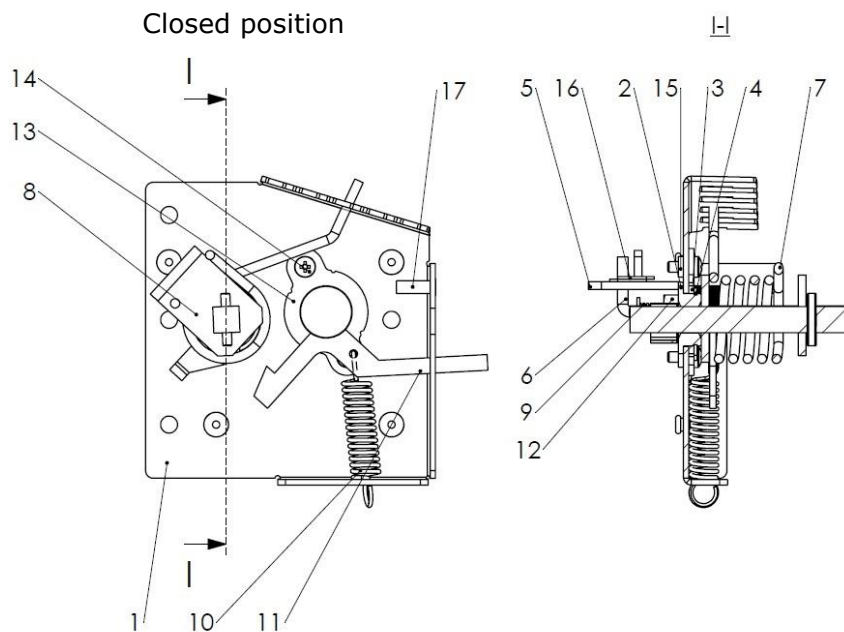

Figure 16. Spring mechanism – replacement of the thermal fuse element

9. COMMISSIONING

After assembling the device and installation into the control system, before putting the smoke control damper into operation, the following actions should be carried out and recorded:

- verify the correct assembly of the damper according to this Technical Documentation;
- check the correctness of the electrical installation in terms of power supply parameters and quality of execution;
- ensure that the damper has not been mechanically damaged during installation;
- verify the correct opening/closing of the damper, with the opening/closing time being maintained below 60 seconds;
- check the cleanliness of the device and ensure that there are no foreign elements present that could damage the device;
- ensure proper accessibility to the drive mechanism and thermal trigger mechanism - required for service and maintenance purposes;
- check the availability and legibility of labeling stickers.

In order to enable efficient verification of the correctness of the assembly and start-up of the KTS-O damper, before putting it into service and documenting the above control activities in the as-built construction documentation, we suggest using (for auxiliary purposes) the document: "Assembly and Start-up Protocol - Fire Flaps".

This protocol is not obligatory to prepare and is only a proposal from the manufacturer of the product in the scope of preparing documentation confirming the execution of assembly and start-up in accordance with the Technical Documentation and Assembly Instructions.

An editable version of the document (universal for all dampers in the SMAY offer) can be downloaded from the manufacturer's website: <https://www.smay.pl/en/>

10. PERIODIC MAINTENANCE AND SERVICING RULES

Before starting any operational and maintenance work, you must familiarize yourself with this documentation. This obligation particularly falls on individuals responsible for operating the device or equipment within the scope of operation, maintenance, and service. In the absence of technical personnel with qualifications specified by the manufacturer, the inspection/maintenance of SMAY devices should be carried out by the SMAY Manufacturer's Service or technical staff of SMAY trading partners appropriate for a given country.

Damage to the KTS-O damper resulting from failure to comply with the guidelines contained in the documentation will not be covered by warranty repairs.

After installing KTS-O fire dampers and with the system activated, it is necessary to conduct regular inspections and record them as presented in the Annual Inspection Protocol - Smoke control dampers / Fire dampers (included below) **no less frequently than every 12 months or in periods resulting from local legislation. If necessary, inspections should be conducted more frequently.**

Technical condition review and maintenance of the device should include:

1. Visual inspection of the damper
 - a) Reading data from the damper rating label
 - b) Assessment of the damper installation condition
 - c) Assessment of the damper housing condition
 - d) Assessment of the partition and drive transmission condition
 - e) Assessment of the condition of the swelling and ventilation seal
 - f) Assessment of the damper cleanliness, cleaning
2. Inspection of the damper drive
 - a) Assessment of the manual mechanism*
 - b) Assessment of the actuator* (compliance of the symbol with the label, warranty seal)
 - c) Assessment of the electrical connection of the damper*
3. Inspection of the damper trigger
 - a) Inspection of the mechanical trigger*
 - b) Inspection of the electrical trigger*
4. Inspection of the damper operation
 - a) Opening and closing the damper
 - b) Assessment of maintaining the open position
 - c) Assessment of correct closure of the damper
 - d) Assessment of correct response to the control signal from the SAP or voltage loss

* if present in the inspected damper type

Technical inspection and service of the device should be documented in an inspection report, an editable version of which is available for download on the manufacturer's website: <https://www.smay.pl/en/>

Failure to implement the above guidelines regarding periodic inspection results in the device not being allowed for further operation. Simultaneously such a device loses the manufacturer's warranty protection in accordance with the OWG

All activities related to the replacement or modification of device components can be carried in agreement with the SMAY manufacturer's service.

Elements that have been factory sealed should have intact original seals applied.

The KTS-O damper does not require any protective measures other than regular maintenance/technical inspections and proper care, including keeping the damper elements clean. The damper can be cleaned using a dry cloth or brush. Dirt and other contaminants can be removed using commonly available cleaning agents. Do not use aggressive, corrosive, or sharp tools.

Below is a list of recommended periodic inspection activities with possible faults. The document is intended to assist in defining identified defects during inspection.

In the housing of fire damper there is an inspection opening, which enables making an inspection and checking the condition of the drive system. inspection opening is sealed by ceramic gasket and it is installed by M5x16 screws.



Figure 17. Inspection opening in KTS-O damper

11. CLASSIFICATION OF DAMPERS FOR REPAIR

The authorized service personnel of the manufacturer or trained companies authorized by them are responsible for removing any detected damages during the periodic inspection. In case of malfunction or damage, the user is obliged to notify the manufacturer or an authorized service company.

After each activation of the damper as a result of a fire action at the facility, it is necessary to assess its technical condition, and consequently qualify it for repair or replacement with a new one. The assessment can only be carried out by the manufacturer's service personnel. Repair work or replacement of the damper after activation due to a fire action at the facility is not covered by the warranty.

12. WARRANTY CONDITIONS

The manufacturer provides a warranty for the delivered products, on the terms set forth in the Agreement or the General Warranty Conditions of Smay, Sp. z o.o. The warranty does not cover defects resulting from improper storage, transportation, installation, and commissioning, operation, periodic maintenance, service, especially mechanical damage and damage to anti-corrosive coatings.

The manufacturer is exempt from warranty obligations if the user introduces structural changes independently, installs the product by the purchaser contrary to the Installation Instructions and Technical Conditions of Sale (Technical Documentation), exceeds the declared durability of the damper, defects due to improper periodic maintenance, and when there is permanent removal of the product nameplate or lack of legibility and verification of the device type.

The General Warranty Conditions (OWG) and General Sales Conditions (OWS) documents are available on the website www.smay.pl



ATTENTION!

Annual Inspection Protocol - Fire Dampers / Smoke Control Dampers:

- **The protocol should be signed by a person holding a valid, personalized certificate or authorization issued by Smay Sp. z o. o., authorizing inspections of fire dampers / smoke control dampers.**
- **In order to maintain the warranty, the employee conducting inspections of SMAY fire dampers / smoke control dampers is required, upon completion of such inspection, to submit the Annual Inspection Protocol to the manufacturer electronically
(www.smay.pl → SERVICE AND WARRANTY tab → ADD COMMISSIONING PROTOCOL)**

The template of the Annual Inspection Protocol - Fire Dampers / Smoke Control Dampers is located at the end of the Technical Documentation.



ATTENTION!

The templates of the forms provided by the SMAY Manufacturer Service and available on the manufacturer's website (concerning assembly, start-up, inspections) are the intellectual property of Smay sp. z o.o. They may not be copied, duplicated or used for purposes other than those specified in this Technical Documentation.