

EXPLOSION-PROOF RECTANGULAR FIRE DAMPER

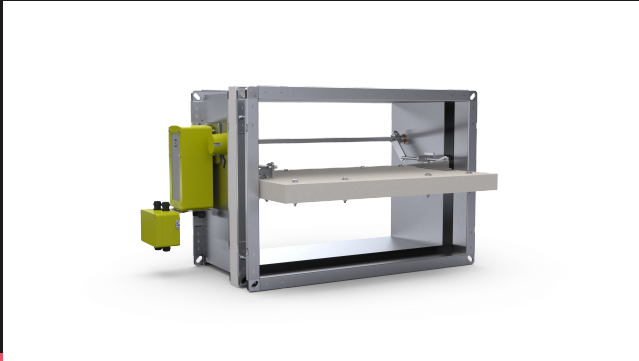

Characteristics:

A fire damper for general ventilation systems with an electric spring return actuator or a spring mechanism with a thermal fuse, intended for Ex explosive atmosphere zones.

version: 18/03/24

Intended use

The KWP-O-Ex fire dampers are designed for application in general ventilation systems as cut-off partitions separating the fire-engulfed zone from the remaining part of the building.

The KWP-O-Ex dampers provide a high degree of safety, and they are designed for use in places where the development of explosive atmosphere, caused by gases, vapours, mists or air and dust mixtures, is likely.

The KWP-O-Ex dampers have been designed and certified according to the 2014/34/EU ATEX Directive, as group II equipment of category 2, designed for use in the explosive atmosphere zones 1, 2, 21 and 22.

The damper fire-proof efficiency was proved with the testing pursuant to the standards: EN ISO 80079-36:2016 and EN ISO 80079-37:2016 and confirmed by the certificate JSHP 22 ATEX 0017X issued by J. S. Hamilton Poland Sp. z o. o. No. AC 149.

KWP-O-Ex dampers have the ATEX marking: II 2G Ex h IIC T6...T5 Gb and II 2D Ex h IIIC T80°C...T95°C Db. Electrical components are ATEX marked according to their certificates.

These dampers are intended to install in horizontally (in walls) and vertically (in ceilings). They can be installed in rigid and flexible building partitions.

The damper is designed, manufactured and tested in accordance with the requirements of the following standards: PN EN 15650 and PN-EN 13501-3. The effectiveness of the dampers is confirmed by tests according to the PN-EN 1366-2 standard.

Classification

Classification of the KWP-O-Ex dampers in terms of fire resistance

The KWP-O-Ex dampers are classified as

EI120(v_e ho i ↔ o) S.

It means the damper fulfils the criteria for fire integrity, fire insulation and smoke leakage for at least 120 minutes.

Classification of the KWP-O-Ex dampers within the scope of the ATEX Directive

Equipment classification: group II, category 2.

Explosive atmosphere zones: 1, 2, 21, 22

ATEX marking:

Ex II 2G Ex h IIC T6...T5 Gb

Ex II 2D Ex h IIIC T80°C...T95°C Db

Description

The damper consists of two housings made of galvanized metal sheet, separated with insulating separators made of 40 mm thick fire-resistant material. The movement of the baffle into the closed position by means of a set of tie rods is limited by a buffer. The axes of the baffle are embedded by slide bearings in the insulating separators. The baffle is closed by means of a set of tie rods.

The permissible air velocity in a BxH connection duct is 12 m/s for the KWP-O-E-Ex damper with an actuator and 8 m/s for the KWP-O-S-Ex damper with a spring mechanism.

Manufacturing versions

KWP-O-E-Ex

A fire damper for ventilation ducts (normally open), with a spring return actuator, with comfort function. The KWP-O-E-Ex fire dampers are driven by means of ExMax-15-BF electric actuator manufactured by SCHISCHEK or ExBF by Belimo housed in an Edelweiss enclosure (supply voltage 24 V AC/DC or 230 V AC). Once the power is supplied to the actuator, the damper opens. The damper is automatically closed due to the trip of the thermal switch whose nominal activation temperature is 72 °C (the thermal switch trip causes a break in the actuator electric circuit). The remote closure of the KWP-O-E-Ex damper is carried out by disconnecting power supply (when a voltage loss occurs, the return spring in the actuator closes the baffle by returning to the non-stressed position).

In the electric actuator with a return spring, microswitches are built-in to signal the position of the damper (open/closed). The damper position can also be read on a mechanical indicator.

During normal system operation, the isolating baffle of a KWP-O-E-Ex damper is in the open position. In the event of an outbreak

of fire the damper baffle rotates to the closed position.

The dimension series of types of the KWP-O-E-Ex fire dampers is limited to the gross surface area of 1.2 m².

KWP-O-S-Ex

A fire damper in explosion-proof version for ventilation ducts (normally open), with a spring actuation system, without the comfort function. The actuation system consists of a spring mechanism combined with a thermal fuse. When the baffle is opened by means of a key, the return spring made of stainless steel wire is tensioned.

Once the specific temperature is exceeded (70±5 °C by default, 95±5 °C optionally), the thermal fuse is destroyed, releasing the hook, and the damper closes.

The current position of the isolating baffle is indicated by the position of the lever relative to the stickers with the "open" and "closed" inscriptions, placed on the damper housing.

During the normal operation of the system the isolating baffle of a KWP-O-S-Ex damper is in the open position.

In the event of an outbreak of fire the damper baffle rotates to the closed position.

The dimension series of types of the KWP-O-S-Ex fire dampers is limited to the gross surface area of 1.0 m².

Dimensions

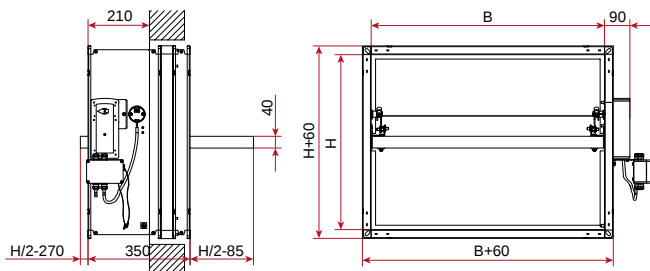

Figure 1. KWP-O-E-Ex damper (with a spring return electric actuator).

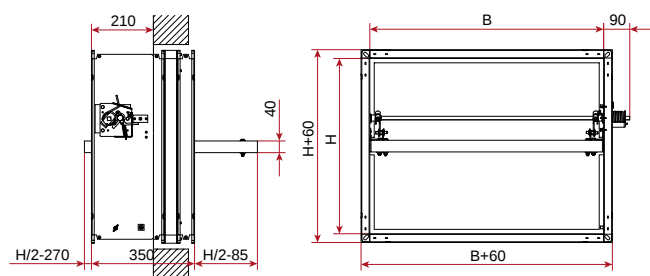
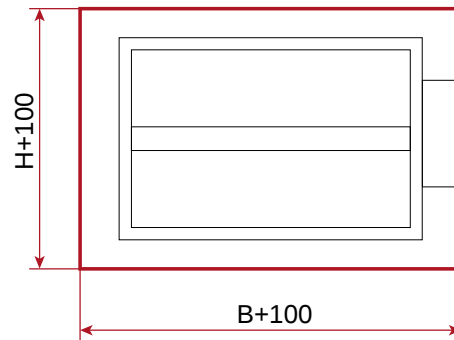

Figure 2. KWP-O-S-Ex damper (with a spring mechanism).

Installation

Rigid wall / flexible wall



Permissible range: B+(210÷250) mm/H+(80÷120) mm

Figure 3. Openings required for the KWP-O-Ex damper.

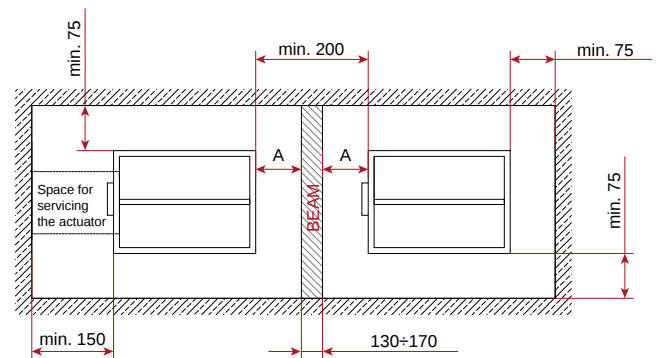

Figure 4. Spacing required between dampers.



The KWP-O-Ex dampers have a ground terminal marked with a label. The user must connect a ground cable at this point.

Technical data

Table 1. The net surface area and the range of actuators used for the KWP-O-Ex dampers.

KWP-O-Ex	Width B [mm]																											
	200	250	300	350	400	450	500	550	600	650	700	750	800	850	900	950	1000	1050	1100	1150	1200	1250	1300	1350	1400	1450	1500	
Height H [mm]	200	0,027	0,035	0,042	0,049	0,056	0,064	0,071	0,078	0,085	0,093	0,100	0,107	0,114*	0,122*	-	-	-	-	-	-	-	-	-	-	-	-	-
	250	0,037	0,046	0,056	0,066	0,076	0,085	0,095	0,105	0,115	0,124	0,134	0,144	0,154	0,163	0,173	0,183*	0,193*	0,202*	-	-	-	-	-	-	-	-	-
	300	0,046	0,058	0,070	0,083	0,095	0,107	0,119	0,132	0,144	0,156	0,168	0,181	0,193	0,205	0,217	0,230	0,242	0,254	0,266	0,279*	0,291*	0,303*	-	-	-	-	-
	350	0,055	0,070	0,085	0,099	0,114	0,129	0,144	0,158	0,173	0,188	0,203	0,217	0,232	0,247	0,262	0,276	0,291	0,306	0,321	0,335	0,350	0,365	0,380	0,394*	0,409*	0,424*	-
	400	0,064	0,082	0,099	0,116	0,133	0,151	0,168	0,185	0,202	0,220	0,237	0,254	0,271	0,289	0,306	0,323	0,340	0,358	0,375	0,392	0,409	0,427	0,444	0,461	0,478	0,496	0,513
	450	0,074	0,093	0,113	0,133	0,153	0,172	0,192	0,212	0,232	0,251	0,271	0,291	0,311	0,330	0,350	0,370	0,390	0,409	0,429	0,449	0,469	0,488	0,508	0,528	0,548	0,567	0,587
	500	0,083	0,105	0,127	0,150	0,172	0,194	0,216	0,239	0,261	0,283	0,305	0,328	0,350	0,372	0,394	0,417	0,439	0,461	0,483	0,506	0,528	0,550	0,572	0,595	0,617	0,639	0,661
	550	0,092*	0,117	0,142	0,166	0,191	0,216	0,241	0,265	0,290	0,315	0,340	0,364	0,389	0,414	0,439	0,463	0,488	0,513	0,538	0,562	0,587	0,612	0,637	0,661	0,686	0,711	0,736
	600	0,101*	0,129	0,156	0,183	0,210	0,238	0,265	0,292	0,319	0,347	0,374	0,401	0,428	0,456	0,483	0,510	0,537	0,565	0,592	0,619	0,646	0,674	0,701	0,728	0,755	0,783	0,810
	650	-	0,140*	0,170	0,200	0,230	0,259	0,289	0,319	0,349	0,378	0,408	0,438	0,468	0,497	0,527	0,557	0,587	0,616	0,646	0,676	0,706	0,735	0,765	0,795	0,825	0,854	0,884
700	-	0,152*	0,184	0,217	0,249	0,281	0,313	0,346	0,378	0,410	0,442	0,475	0,507	0,539	0,571	0,604	0,636	0,668	0,700	0,733	0,765	0,797	0,829	0,862	0,894	0,926*	0,958*	
750	-	0,164*	0,199	0,233	0,268	0,303	0,338	0,372	0,407	0,442	0,477	0,511	0,546	0,581	0,616	0,650	0,685	0,720	0,755	0,789	0,824	0,859	0,894	0,928*	0,963*	0,998*	1,033*	
800	-	-	0,213*	0,250	0,287	0,325	0,362	0,399	0,436	0,474	0,511	0,548	0,585	0,623	0,660	0,697	0,734	0,772	0,809	0,846	0,883	0,921	0,958*	0,995*	1,032*	1,070*	1,107*	
850	-	-	0,227*	0,267	0,307	0,346	0,386	0,426	0,466	0,505	0,545	0,585	0,625	0,664	0,704	0,744	0,784	0,823	0,863	0,903	0,943*	0,982*	1,022*	1,062*	1,102*	-	-	
900	-	-	0,241*	0,284*	0,326	0,368	0,410	0,453	0,495	0,537	0,579	0,622	0,664	0,706	0,748	0,791	0,833	0,875	0,917	0,960*	1,002*	1,044*	1,086*	-	-	-	-	
950	-	-	-	0,300*	0,345	0,390	0,435	0,479	0,524	0,569	0,614	0,658	0,703	0,748	0,793	0,837	0,882	0,927	0,972*	1,016*	1,061*	1,106*	-	-	-	-	-	
1000	-	-	-	0,317*	0,364	0,412	0,459	0,506	0,553	0,601	0,648	0,695	0,742	0,790	0,837	0,884	0,931	0,979*	1,026*	1,073*	1,120*	-	-	-	-	-	-	

* only possible for the KWP-O-E-Ex dampers (with an electric actuator)

0.123 - ExMax-15-BF actuator or BF actuator in Edelweiss Ex housing

The standard length of KWP-O-E-Ex dampers: L = 350

On request, we can manufacture any intermediate size of the damper within the range of the type series.

Table 2. Pressure drop on KWP-O-Ex damper, Δp [Pa].

KWP-O-Ex	v [m/s]	Width B [mm]														
		200	300	400	500	600	700	800	900	1000	1100	1200	1300	1400	1500	
Height H [mm]	200	4	12	12	10	10	10	10	8	-	-	-	-	-	-	-
		6	25	25	22	22	22	22	20	-	-	-	-	-	-	-
		8	45	46	40	40	40	40	38	-	-	-	-	-	-	-
		10	68	68	60	60	60	60	56	-	-	-	-	-	-	-
	300	4	8	8	7	7	7	6	6	6	6	5	5	-	-	-
		6	18	18	15	15	15	13	13	13	13	11	11	-	-	-
		8	32	32	27	27	27	24	24	24	24	22	22	-	-	-
		10	48	48	41	41	41	35	35	35	35	30	30	-	-	-
	400	4	7	7	6	6	6	5	5	5	5	5	5	5	5	4
		6	15	15	13	13	13	11	11	11	11	11	11	11	11	9
		8	27	27	24	24	24	20	20	20	20	20	20	20	20	17
		10	41	41	35	35	35	30	30	30	30	30	30	30	30	26
	500	4	7	7	6	5	5	5	5	4	4	4	4	4	4	4
		6	14	13	13	11	11	11	11	9	9	9	9	9	9	9
		8	25	24	24	20	20	20	20	16	16	16	16	18	18	18
		10	38	35	35	30	30	30	30	24	24	24	24	24	24	24
	600	4	7	6	5	5	4	4	4	4	3	3	3	3	4	4
		6	14	13	11	11	9	9	9	9	7	7	7	7	9	9
		8	26	24	20	20	16	16	16	16	12	12	12	14	18	18
		10	40	35	30	30	24	24	24	24	18	18	18	18	24	24
	700	4	-	5	5	4	4	4	3	3	3	3	3	3	3	3
		6	-	11	11	9	9	9	7	7	7	7	7	7	7	7
		8	-	20	20	16	16	16	12	12	12	12	12	14	14	14
		10	-	30	30	24	24	24	18	18	18	18	18	18	18	18
	800	4	-	5	5	4	4	4	3	3	3	3	3	2	3	3
		6	-	11	11	9	9	9	7	7	7	7	7	5	7	7
		8	-	20	20	16	16	16	12	12	12	12	12	10	14	14
		10	-	30	30	24	24	24	18	18	18	18	18	12	18	18
	900	4	-	5	4	4	4	3	3	3	3	3	2	2	-	-
		6	-	11	9	9	9	7	7	7	7	7	5	5	-	-
		8	-	20	16	16	16	12	12	12	12	12	8	10	-	-
		10	-	30	24	24	24	18	18	18	18	18	12	12	-	-
	1000	4	-	-	4	4	3	3	3	3	3	2	2	-	-	-
		6	-	-	9	9	7	7	7	7	7	5	5	-	-	-
		8	-	-	16	16	12	12	12	12	12	8	8	-	-	-
		10	-	-	24	24	18	18	18	18	18	12	12	-	-	-

v [m/s] - air flow velocity in the BxH connection duct

Table 3. Sound power level emitted by the KWP-O-Ex damper to the duct, L_{WA} [dB(A)].

KWP-O-Ex	w [m/s]	Width B [mm]														
		200	300	400	500	600	700	800	900	1000	1100	1200	1300	1400	1500	
Height H [mm]	200	4	13	16	19	20	21	22	23	-	-	-	-	-	-	-
		6	21	24	27	28	30	30	32	-	-	-	-	-	-	-
		8	30	33	36	37	38	39	41	-	-	-	-	-	-	-
		10	38	41	43	45	46	47	49	-	-	-	-	-	-	-
	300	4	17	20	23	24	26	27	28	29	29	30	31	-	-	-
		6	25	29	31	32	34	35	36	37	37	38	40	-	-	-
		8	34	37	39	41	42	43	44	45	46	47	48	-	-	-
		10	42	45	47	49	50	51	52	53	54	55	57	-	-	-
	400	4	20	23	25	27	28	29	30	31	32	32	33	34	35	35
		6	28	31	33	35	36	38	39	39	40	41	41	42	43	43
		8	36	40	42	43	45	46	47	47	48	49	49	50	51	52
		10	45	48	50	51	53	54	55	55	56	57	57	58	59	59
	500	4	22	25	27	29	30	31	32	33	34	34	35	36	37	38
		6	30	33	35	37	38	39	40	41	42	43	43	44	44	46
		8	37	41	44	45	46	48	48	49	50	51	51	52	51	53
		10	45	49	52	53	54	56	56	57	58	59	59	59	59	61
	600	4	23	26	28	30	31	33	33	34	35	36	36	37	39	39
		6	31	34	37	38	40	41	42	43	44	44	45	45	45	48
		8	40	43	45	47	48	49	50	51	51	52	53	53	53	55
		10	48	51	53	55	56	57	58	59	59	60	61	60	60	63
	700	4	-	28	30	31	33	34	35	36	36	37	38	38	40	40
		6	-	36	38	40	41	42	43	44	45	45	46	46	46	49
		8	-	44	46	48	49	50	51	52	53	53	54	54	54	56
		10	-	52	54	56	57	58	59	60	60	61	62	61	62	64
	800	4	-	29	31	32	34	35	36	37	37	38	39	39	41	41
		6	-	37	39	41	42	43	44	45	46	46	47	47	47	50
		8	-	45	47	49	50	51	52	53	54	54	55	55	55	57
		10	-	53	55	57	58	59	60	61	61	62	63	62	63	65
	900	4	-	29	31	33	34	36	37	37	38	39	40	40	-	-
		6	-	38	40	42	43	44	45	46	47	47	48	48	-	-
		8	-	46	48	50	51	52	53	54	54	55	56	56	-	-
		10	-	54	56	58	59	60	61	62	62	63	64	63	-	-
	1000	4	-	-	33	34	35	36	37	38	39	40	41	-	-	-
		6	-	-	41	42	44	45	46	47	47	48	49	-	-	-
		8	-	-	49	50	52	53	54	54	55	56	57	-	-	-
		10	-	-	57	58	60	61	62	62	63	64	65	-	-	-

v [m/s] - air flow velocity in the BxH connection duct

Table 4. Weight of KWP-O-E-Ex damper, m [kg].

KWP-O-E-Ex		Width B [mm]													
		200	300	400	500	600	700	800	900	1000	1100	1200	1300	1400	1500
Height H [mm]	200	11,9	14,2	16,4	18,6	20,8	23,0	25,2	-	-	-	-	-	-	-
	300	14,0	16,6	19,3	21,8	24,4	27,0	29,7	32,6	35,3	38,0	40,7	-	-	-
	400	16,2	19,2	22,2	25,2	28,2	31,5	34,6	37,6	40,7	43,7	46,7	55,1	58,5	61,9
	500	18,3	21,7	25,2	28,6	32,3	35,7	39,2	42,6	46,0	49,4	52,9	62,1	65,8	70,9
	600	20,3	24,2	28,1	32,2	36,0	39,8	43,7	47,5	51,3	55,2	59,0	70,3	74,4	78,6
	700	-	26,7	31,3	35,4	39,7	43,9	48,2	52,4	56,6	62,2	66,4	77,1	81,7	86,2
	800	-	29,2	34,2	38,8	43,4	48,0	52,7	57,3	63,3	68,0	72,6	84,0	89,0	93,9
	900	-	32,0	37,1	42,0	47,1	52,1	57,2	63,6	68,6	73,7	78,7	90,9	96,2	-
	1000	-	-	40,0	45,4	50,9	56,3	63,2	68,6	74,1	79,5	84,9	-	-	-

Table 5. Weight of KWP-O-S-Ex damper, m [kg].

KWP-O-S-Ex		Width B [mm]													
		200	300	400	500	600	700	800	900	1000	1100	1200	1300	1400	1500
Height H [mm]	200	11,8	14,0	16,2	18,4	20,6	22,8	-	-	-	-	-	-	-	-
	300	13,8	16,5	19,1	21,7	24,3	26,9	29,6	32,0	34,4	36,8	-	-	-	-
	400	16,0	19,0	22,1	25,0	28,0	31,1	34,1	36,9	40,0	43,1	46,2	49,3	52,4	55,5
	500	18,2	21,6	25,0	28,4	31,8	35,2	38,7	42,3	45,7	49,1	52,5	55,9	59,3	62,7
	600	-	23,8	27,7	31,5	35,3	39,5	43,4	47,2	51,1	55,0	58,9	62,8	66,7	70,6
	700	-	26,3	30,6	34,8	39,4	43,6	47,9	52,1	56,4	60,7	65,0	69,3	73,6	-
	800	-	-	33,5	38,1	43,1	47,7	52,4	57,1	61,7	66,3	70,9	-	-	-
	900	-	-	36,4	41,8	46,8	51,8	56,9	62,0	67,0	72,0	-	-	-	-
	1000	-	-	39,4	45,2	50,6	56,0	61,5	67,0	72,4	-	-	-	-	-



The safety requirements in regard to the construction of the KWP- EX fire dampers series designed for the use in places where explosive atmospheres may occur, have been confirmed by a certificate issued by the J.S. Hamilton Poland Sp. z o.o.

Conforms to the requirements of:

PN-EN 15650 "Ventilation for buildings – Fire dampers"

PN-EN 13501-3 "Fire classification of construction products and building elements – Part 3: Classification using data from fire resistance tests on products and elements used in building service installations: fire resisting ducts and fire dampers."

KWP-O-EX - Explosion-proof rectangular fire damper

When ordering, please provide information in accordance with the following pattern:

KWP-O - <F> - Ex - x <H> - <L> - <S> - <P>

Where:

F	type of the actuation system used
	E - electric spring return
	S - spring mechanism
B	damper clear width [mm]
H	damper clear height [mm]
L	damper length – L = 350 by default, [optionally L = 600 mm]
S	type of actuator used (KWP-O-E-Ex dampers only)*
	ExMax-15-BF - ExMax-15-BF actuator manufactured by SCHISCHEK
	ExBF - BF actuator manufactured by Belimo in an Ex EDELWEISS housing
P	material*
	none - galvanized steel
	SN - stainless steel

* optional items – if not indicated, default values will be used

Order example: **KWP-O-E-Ex-500x300**